

VL2416™ Wash Luminaire



USER'S MANUAL

VARI*LITE® is a trademark owned by Genlyte Thomas Group LLC and is registered in the United States and other countries.

VL1000™, VL2000™, VL2201™, VL2202™, VL2400™ (and the individual product designations), **VL3000™, Series 1000™, Series 2000™, Series 3000™, DICHRO*TUNE™, VARI*IMAGE™**, and the Vari-Lite Asterisk are also trademarks owned by Genlyte Thomas Group LLC.

VARI*LITE® products are protected by one or more of the following patents, and other pending patent applications worldwide:

U. S. Patents No. 6,123,436; 6,113,252; 6,046,861; 6,031,749; 6,011,640; 5,969,868; 5,959,768; 5,934,794; 5,882,107; 5,829,868; 5,825,548; 5,798,619; 5,774,273; 5,769,527; 5,758,956; 5,728,994; 5,640,061; 5,590,954; 5,454,477; 5,432,691; 5,367,444; 5,329,431; 5,307,295; 5,282,121; 5,278,742; 5,209,560; 5,186,536; 5,073,847; 5,010,459; 4,980,806; 4,972,306; 4,800,474; 4,779,176; 4,701,833; 4,602,321;

U. S. Design Patents No. 439,356; 420,332; 417,300; 415,301; 413,995; 377,338; 366,712; 359,574; 350,408; 347,113;

Australia Patents No. 693,691; 683,695; 667,109; 649,264; 646,588; 586,095; 576,400; 546,433;

Australia Design Patents No. 128,796; 128,795;

Canada Patents No. 2,070,670; 2,050,375; 1,270,675; 1,259,058; 1,181,795;

Canada Design Patents No. 81,234; 81,233; 76,046;

European (UK) Patents No. 0 652 400; 0 586 049; 0 565 218; 0 547 732; 0 534 710; 0 495 305; 0 474 202; 0 379 970; 0 253 082; 0 253 081; 0 248 974; 0 192 882; 0 140 994; 0 060 068;

Germany Patents No. 694 25 943.8; 693 14 122.0; 692 08 615.3; 692 07 692.1; 691 31 478.0; 691 21 029.2; 690 33 385.4; 37 89 166.9; 37 68 727.1; 37 51 804.6; 37 50 201.8; 35 87 270.5; 32 79 888.1; 32 74 291.6;

Germany Design Patents No. M 98 01 745.4; M 96 04 515.9; M 96 04 514.0; M 94 07 689.8; M 94 02 951.2; M 499 03 583.6; M 498 11 203.9; G 93 12 884.3;

Spain Patents No. 2 090 191; 2 084 289; 2 020 960; 0 548 328;

Spain Utility Model Patent No. 2.031.748;

Spain Design Patents No. 0.137.502; 0.137.501; 0.133.573;

Greece Patent No. 910.400.544;

Hong Kong Patents No. 965/1990; 285/1987;

Japan Patents No. 2,843,696; 2,059,669; 2,055,324; 2,002,168; 1,966,525; 1,889,481; 1,792,721; 1,770,241; 1,723,825; 1,683,007; 1,533,011;

Japan Design Patents No. 985,985-1; 985,985; 947,552; 945,436-1; 945,436; 1,106,089; 1,077,598; 1,072,598; 1,060,414; 1,002,123;

Korea Patents No. 76,310; 42,639; 283,770; 181,180;

Korea Design Patents No. 209,896; 209,895;

Mexico Patent No. 180,148;

Singapore Patents No. 663/90; 134/87;

Taiwan Patents No. 78,726; 66,975; 65,380; 28,275;

United Kingdom Design Registrations No. 2082526; 2072562; 2056387; 2056386; 2042174; 2038212; 2033108; 2029499.

Neutrik®, PowerCon®, and EtherCon® are registered trademarks of Neutrik, Inc.

All other brand or product names which may be mentioned in this manual are trademarks or registered trademarks of their respective companies or organizations.

VL2416™ Wash Luminaire User's Manual

The information furnished in this manual is for informational use only and is subject to change without notice. Please check www.vari-lite.com for latest version. Vari-Lite assumes no responsibility or liability for any errors or inaccuracies that may appear in this manual. All information and graphics are property of Genlyte Thomas Group LLC, 10911 Petal St. Dallas, TX 75238.

Version as of: 09-Apr-03

Part number: 02.9661.0001 K

How To Obtain Warranty Service

A copy of the Vari-Lite Limited Warranty was included in the shipping package for this VARI*LITE® product.

To obtain warranty service, please contact customer service at 1-877-VARI-LITE (1-877-827-4548) or customerservice@vari-lite.com and request a Return Material Authorization (RMA) for warranty service. You will need to provide the model and serial number of the item being returned, a description of the problem or failure and the name of the registered user or organization. If available, you should have your sales invoice to establish the date of sale as the beginning of the warranty period.

Once you obtain the RMA, pack the unit in a secure shipping container or in its original packing box. Fill out the RMA form included at the end of this manual and place in shipping container along with a copy of your invoice (if available). Write the RMA number legibly on or near the shipping address label and return the unit, freight prepaid to:

Vari-Lite
10911 Petal St.
Dallas, TX 75238
Attention: Warranty Service

As stated in the warranty, it is required that the shipment be insured and FOB our service center.

Compliance Notice

FCC This equipment has been tested and found to comply with the limits for a Class A digital device pursuant to Part 15 of FCC Rules. These limits are designed to provide reasonable protection against harmful interference when this equipment is operated in a commercial environment. This equipment generates, uses, and can radiate radio frequency energy and, if not installed and used in accordance with Vari-Lite system, service, and safety guidelines, may cause harmful interference to radio communications. Operation of this equipment in a residential area is likely to cause harmful interference, in which case the user will be required to correct the interference at his/her own expense.



Declaration of Conformity

We declare, under our sole responsibility, that this product complies with the relevant clauses of the following standards and harmonized documents:

Safety

EN 60598-1:1997 Luminaire Safety Standard, General Requirements

EN 60598-2 17:1989 Specification for Luminaires for Stage and Studio Lighting

EMC

EN 55022A:1994 Radiated and Conducted Emissions

EN 50082-1:1997 Generic Immunity Standard

We certify that the product conforms to the protection requirements of council directives: 73/23/EEC (LVD) and 89/336/EEC (EMC)

Safety Notice

It is extremely important to read ALL safety information and instructions provided in this manual and any accompanying documentation before installing and operating the products described herein. Heed all cautions and warnings during installation and use of this product.

Safety symbols used throughout this manual are as follows:



CAUTION advising of potential damage to product.



WARNING advising of potential injury or death to persons.

GENERAL INFORMATION PERTAINING TO PROTECTION AGAINST ELECTRICAL SHOCK, FIRE, EXPOSURE TO EXCESSIVE UV RADIATION, AND INJURY TO PERSONS CAN BE FOUND BELOW.

WARNING:

INSTRUCTIONS FOR CONTINUED PROTECTION AGAINST FIRE

1. VARI*LITE® luminaires have been designed for use with specific lamp types. The VL2416 wash luminaire requires a 1200 Watt short arc lamp. Installing another type of lamp may be hazardous.
2. Luminaires may be mounted on any type of surface as long as mounting instructions are followed. See instructions detailed in this manual.
3. Note distance requirement from combustible materials or illuminated objects for VARI*LITE® luminaires.

WARNING:

INSTRUCTIONS FOR CONTINUED PROTECTION AGAINST ELECTRICAL SHOCK

1. VARI*LITE® luminaires are designed for dry locations only. Exposure to rain or moisture may damage luminaire.
2. Disconnect power before servicing any VARI*LITE® equipment.
3. Servicing to be performed by qualified personnel only.

WARNING:

INSTRUCTIONS FOR CONTINUED PROTECTION AGAINST EXCESSIVE EXPOSURE TO UV RADIATION

1. Many VARI*LITE® luminaires use a lamp that produces UV radiation. DO NOT look directly at lamp.
2. It is hazardous to operate luminaires without lens or shield. Shields, lenses, or ultraviolet screens shall be changed if they have become visibly damaged to such an extent that their effectiveness is impaired. For example, by cracks or deep scratches.

WARNING:

INSTRUCTIONS FOR PROTECTION AGAINST INJURY TO PERSONS

1. Exterior surfaces of the luminaire will be hot during operation. Use appropriate safety equipment (gloves, eye protection, etc.) when handling and adjusting hot equipment and components.
2. Luminaires will have a hot lamp when operating. Disconnect power and allow lamp to cool before replacing.
3. Arc lamps emit ultraviolet radiation which can cause serious skin burn and eye inflammation. Additionally, arc lamps operate under high pressure at very high temperatures. Should the lamp break, there can exist a danger of personal injury and/or fire from broken lamp particles being discharged.
4. Wear eye protection when relamping.
5. Appropriate safety equipment (gloves, eye protection) should be used when handling damaged lamps.
6. If lamp is touched with bare hands, clean lamp with denatured alcohol and wipe with lint-free cloth before installing or powering up the luminaire.
7. The lamp shall be changed if it has become damaged or thermally deformed.

WARNING:

RF INTERFERENCE

1. This is a Class A product. In a domestic environment this product may cause radio interference, in which case, the user may be required to take adequate measures.

ARC LAMP CHARACTERISTIC CONSIDERATIONS

1. Arc lamps require a period of time to relight after a power interruption or a severe voltage dip. In some cases, lamp will automatically relight after it has cooled depending on Lamp Power-Up State configuration setting.
2. Burning position is Universal.

Sicherheitshinweise

Es ist äußerst wichtig, ALLE Sicherheitsinformationen und -hinweise in diesem Handbuch und dem beiliegenden Informationsmaterial zu lesen, bevor Sie die hierin beschriebenen Produkte installieren bzw. bedienen. Halten Sie bei der Installation und dem Einsatz dieses Produkts alle Warnhinweise und Vorsichtsmaßnahmen ein.

Folgende Sicherheitssymbole werden in diesem Handbuch verwendet:



VORSICHT - weist auf möglichen Produktschaden hin.



WARNUNG - weist auf mögliche Körperverletzung und Lebensbedrohung hin.

NACHSTEHEND FINDEN SIE ALLGEMEINE HINWEISE ÜBER SICHERHEITSVORKEHRUNGEN GEGEN ELEKTROSCHOCK, FEUER, ÜBERHÖHTE UV-STRAHLUNG UND KÖRPERVERLETZUNGEN.

WARNUNG:

HINWEISE ZUM FEUERSCHUTZ

1. VARI*LITE®-Scheinwerfer sind ausschließlich für den Einsatz mit bestimmten Lampentyps. Achten Sie auf den Lampentyp (1200 Watt short arc lamp), bevor Sie die jeweiligen Lampen ersetzen. Die Installation eines anderen Lampentyps kann gefährlich sein.
2. Scheinwerfer können auf jeder beliebigen Oberfläche montiert werden, solange Sie die Montageanweisungen befolgen. Detaillierte Hinweise finden Sie in diesem Handbuch.
3. Beachten Sie die Einhaltung des erforderlichen Sicherheitsabstandes der VARI*LITE®-Scheinwerfer von brennbarem Material oder beleuchteten Objekten.

WARNUNG:

HINWEISE ZUM SCHUTZ GEGEN ELEKTROSCHOCK

1. VARI*LITE®-Scheinwerfer eignen sich ausschließlich für trockene Standorte. Regen oder Feuchtigkeit können die Scheinwerfer beschädigen.
2. Unterbrechen Sie die Stromzufuhr, bevor Sie mit der Arbeit an VARI*LITE®-Geräten beginnen.
3. Die Geräte sollten nur von qualifiziertem Personal gewartet werden.

WARNUNG:

HINWEISE ZUM SCHUTZ GEGEN ÜBERHÖHTE UV-STRAHLUNG

1. Viele VARI*LITE®-Scheinwerfer verwenden die Lampentyp, der UV-Strahlen abgibt. SCHAUEN SIE NICHT direkt in die Lampe.
2. Es ist gefährlich, Leuchten ohne Linsen oder Blenden zu bedienen. Blenden, Linsen oder Ultraviolettshielder müssen ausgetauscht werden, sofern deren Schutzwirkung durch sichtbare Beschädigung (z. B. Sprünge oder Schrammen) eingeschränkt ist.

WARNUNG:

HINWEISE ZUM SCHUTZ GEGEN KÖRPERVERLETZUNGEN

1. Bei Betrieb sind die Außenflächen der Scheinwerfer heiß. Verwenden Sie bei der Bedienung von aufgeheizter Apparatur die jeweils geeignete Sicherheitsausrüstung (Handschuhe, Augenschutz etc.).
2. Bei Betrieb der Scheinwerfer ist die Lampe heiß. Unterbrechen Sie die Stromzufuhr und lassen Sie die Lampe abkühlen, wenn Sie diese austauschen.
3. Bogenlampen senden ultraviolette Strahlen aus, die Hautverbrennungen und Augenentzündungen verursachen können. Der Betrieb von Bogenlampen erfolgt unter Hochdruck und bei hohen Temperaturen. Sollte die Lampe zerbrechen, besteht die Gefahr von Körperverletzung bzw. von Feuer, das von Lampenteilen ausgelöst werden kann.
4. Tragen Sie beim Austausch der Lampen einen Augenschutz.
5. Die geeignete Sicherheitsausrüstung (Handschuhe, Augenschutz) sollte beim Umgang mit beschädigten Lampen verwendet werden.
6. Wenn die Lampe mit bloßen Händen berührt wird, reinigen Sie sie mit denaturiertem Alkohol und einem fusenfreien Tuch, bevor Sie die Scheinwerfer installieren oder in Betrieb nehmen.
7. Wenn die Lampe beschädigt oder durch Hitzeeinwirkung deformiert ist, muß diese ausgetauscht werden.

WARNUNG:

HF-INTERFERENZ

1. Es handelt sich um ein Produkt der Klasse A. In einer Wohnumgebung kann das Produkt Hochfrequenzstörungen verursachen. In diesem Fall müssen eventuell geeignete Maßnahmen getroffen werden.

BESONDERHEITEN VON BOGENLAMPEN

1. Bogenlampen benötigen eine gewisse Zeitdauer, um nach einem Stromausfall oder einem Spannungsgefälle wieder aufzuleuchten. In einigen Fällen wird die Lampe nach Abkühlung automatisch wieder aufleuchten, je nach der Systemkonfigurationseinstellung des Lampeneinschaltungsstatus.
2. Die Brennposition ist Universal.

Notes de sécurité

Avant de procéder à l'installation des produits décrits dans ce guide et de les mettre en marche, il est extrêmement important de lire TOUS les renseignements et TOUTES les directives de sécurité contenues dans ce guide ainsi que toute documentation jointe. Tenir compte de tous les avertissements et suivre toutes les précautions pendant l'installation et l'utilisation de cet appareil.

Les symboles de sécurité utilisés dans ce guide sont les suivants :



ATTENTION Ce symbole annonce que l'appareil risque d'être endommagé.



AVERTISSEMENT Ce symbole annonce qu'il y a risque d'accident grave ou même fatal.

CETTE SECTION CONTIENT DES INFORMATIONS GÉNÉRALES POUR SE PROTÉGER CONTRE LES DÉCHARGES ÉLECTRIQUES, LES INCENDIES, L'EXPOSITION EXCESSIVE AUX RAYONS UV ET TOUT AUTRE ACCIDENT POUVANT ENTRAÎNER DES BLESSURES.

AVERTISSEMENT:

DIRECTIVES POUR SE PROTÉGER CONTRE LES INCENDIES

1. Les luminaires VARI*LITE® ont été conçus pour être utilisés uniquement avec certaines type de lampes. Vérifier le type de lampe (1200 Watt short arc lamp) avant de remplacer les lampes. L'installation d'un autre type de lampe peut poser un danger.
2. Les luminaires peuvent être fixés sur tout type de surface tant que les directives de montage sont respectées. Voir les explications détaillées dans ce guide.
3. Vérifier la distance à respecter entre les matériaux combustibles ou les objets illuminés et les luminaires VARI*LITE®.

AVERTISSEMENT:

DIRECTIVES POUR SE PROTÉGER CONTRE LES DÉCHARGES ÉLECTRIQUES

1. Les luminaires VARI*LITE® sont conçus pour une utilisation au sec uniquement. Une exposition à la pluie et à l'humidité risque d'endommager le luminaire.
2. Débrancher l'appareil avant de procéder à la révision de tout matériel VARI*LITE®.
3. Les révisions doivent être effectuées uniquement par des personnes qualifiées.

AVERTISSEMENT:

DIRECTIVES POUR SE PROTÉGER CONTRE UNE EXPOSITION EXCESSIVE AUX RAYONS UV

1. Plusieurs luminaires VARI*LITE® utilisent une lampe qui produit des rayons UV. NE PAS fixer son regard sur la lampe.
2. L'utilisation des luminaires sans lentille ou blindage pose des risques. Tous blindages, lentilles ou écrans ultraviolet visiblement endommagés au point que leur efficacité en est affectée doivent être remplacés, par exemple s'il y a des fissures ou de profondes rayures.

AVERTISSEMENT:

DIRECTIVES POUR SE PROTÉGER CONTRE LES ACCIDENTS POUVANT ENTRAÎNER DES BLESSURES

1. Les surfaces externes du luminaire deviennent brûlantes quand l'appareil est en marche. Pour manœuvrer ou ajuster des appareils brûlants et leurs composants, se protéger suffisamment (gants, protection pour les yeux, etc.).
2. La lampe du luminaire est brûlante lorsqu'il est en marche. Débrancher le courant et attendre que la lampe ait refroidi avant de la remplacer.
3. Les lampes à arc émettent des rayons ultraviolets pouvant causer de graves brûlures sur la peau et une inflammation des yeux. De plus, les lampes à arc fonctionnent sous haute tension à de très hautes températures. Si la lampe se casse, les particules de la lampe cassée peuvent causer blessures et/ou incendie en s'éparpillant.
4. Se protéger les yeux pour remplacer la lampe.
5. Utiliser des appareils de protection appropriés (gants, protection des yeux) pour manier des lampes endommagées.
6. Si la lampe a été touchée avec des mains nues, la nettoyer avec de l'alcool dénaturé et l'essuyer avec un chiffon non-pelucheux avant d'installer ou de brancher le luminaire.
7. Si la lampe a été endommagée ou a reçu une déformation thermique, elle doit être remplacée.

AVERTISSEMENT:

INTERFÉRENCE RF

1. Cet appareil est de Classe A. Dans un environnement domestique, cet appareil peut causer des interférences radio, et si c'est le cas, l'utilisateur peut avoir à prendre des mesures adéquates.

CONSIDÉRATIONS DES CARACTÉRISTIQUES DE LAMPES À ARC

1. Après une interruption de courant ou une baisse importante de voltage, les lampes à arc mettent du temps avant de se rallumer. Dans certains cas, la lampe se rallumera automatiquement après s'être refroidie. Cela dépend de la manière dont le système est réglé pour le statut de mise en marche de la lampe.
2. La position Brûler est Universelle.

Aviso sobre Seguridad

Es muy importante leer TODA la información e instrucciones sobre seguridad que se indica en este manual así como en los documentos adjuntos antes de instalar y operar los productos descritos. Se debe prestar atención a todos los avisos y advertencias durante la instalación y uso de este producto.

Los símbolos de seguridad usados en este manual son los siguientes:



CUIDADO, indica posibles daños al producto.



ADVERTENCIA, indica posibles lesiones o muerte a las personas.

LA INFORMACIÓN GENERAL RELACIONADA A LA PROTECCIÓN CONTRAGOLPES DE CORRIENTE ELÉCTRICA, INCENDIO, EXPOSICIÓN EXCESIVA A RADIACIÓN ULTRA VIOLETA Y LESIONES A LAS PERSONAS SE PUEDE ENCONTRAR SEGUIDAMENTE:

ADVERTENCIA:

INSTRUCCIONES PARA PROTECCIÓN CONTINUA CONTRA INCENDIO

1. Las luminarias VARI*LITE® han sido diseñadas para ser usadas solamente con algunas lámparas. Tome nota del tipo de lámpara (1200 Watt short arc lamp) antes de reemplazarla. Instalación de otro tipo de lámpara puede ser peligroso.
2. Las luminarias se pueden instalar en cualquier tipo de superficie siempre que se sigan las instrucciones de instalación. Vea las instrucciones detalladas en este manual.
3. Tome nota de los requerimientos de distancia de materiales combustibles u objetos iluminados para las luminarias VARI*LITE®.

ADVERTENCIA:

INSTRUCCIONES PARA PROTECCIÓN CONTINUA CONTRA CHOQUE ELÉCTRICO

1. Las luminarias VARI*LITE® están diseñadas solamente para lugares secos. La exposición a la lluvia o humedad pueden dañar la luminaria.
2. Desconecte la energía antes de dar servicio a cualquier equipo de VARI*LITE®.
3. El servicio debe ser realizado solamente por personal calificado.

ADVERTENCIA:

INSTRUCCIONES PARA PROTECCIÓN CONTINUA CONTRA LA EXPOSICIÓN EXCESIVA DE RADIACIÓN ULTRA VIOLETA

1. Muchas luminarias VARI*LITE® usan un tipo de lámpara que produce radiación UV. NO mire directamente a la lámpara.
2. Es peligroso operar luminarias sin lentes o protectores. Debe cambiar los protectores, lentes o pantallas ultravioletas si se aprecia que han sido dañadas, y que su efectividad pudiera estar deteriorada. Por ejemplo, si tuvieran rajaduras o raspaduras profundas.

ADVERTENCIA:

INSTRUCCIONES PARA PROTECCIÓN CONTRA LESIONES DE PERSONAS

1. Las superficies exteriores de las luminarias están calientes durante su operación. Use un equipo de seguridad apropiado (guantes, protección para los ojos, etc.) cuando haga ajustes en el equipo y componentes que están calientes.
2. Cuando las luminarias están en operación la lámpara estará muy caliente. Desconecte la energía y deje que la lámpara se enfríe antes de reemplazarla.
3. Las lámparas de arco emiten radiaciones ultravioletas que pueden ocasionar serias quemaduras a la piel e inflamación a los ojos. Además, las lámparas de arco operan a alta presión y muy alta temperatura. Si la lámpara se rompe, puede existir el peligro de lesiones al personal o un incendio ocasionado por las partículas de la lámpara rota que se caen.
4. Use protección para los ojos cuando vuelve a colocar una lámpara nueva.
5. Use un equipo de seguridad apropiado (guantes, protección para los ojos, etc.) cuando trabaje con lámparas dañadas.
6. Si toca la lámpara con las manos, limpie la lámpara con alcohol desnaturalizado y con tela sin pelusas antes de instalar o volver a conectar la luminaria.
7. Cambie la lámpara si está dañada o deformada termicamente.

ADVERTENCIA:

INTERFERENCIA RF

1. Este es un producto de Clase A. En el ambiente de la casa este producto puede ocasionar radiointerferencia, en cuyo caso, el usuario debe tomar las medidas adecuadas.

CONSIDERACIONES SOBRE LAS CARACTERÍSTICAS DE LA LÁMPARA DE ARCO

1. Las lámparas de arco requieren un período de tiempo para volver a iluminarse después de una interrupción de energía o de una severa caída de voltaje. En algunos casos, la lámpara se volverá a iluminar en forma automática después que se ha enfriado dependiendo de la configuración del sistema de energía de la lámpara.
2. La posición de encendido es universal.

安全性に関する注意事項

ここに記載されている製品を取り扱う場合は、まず本マニュアルおよび付属のマニュアルの安全性に関する情報と説明をすべてお読みください。また、実際に本製品を取り付けたり使用する際には、すべての注意事項および警告に留意して作業してください。

本マニュアルでは、以下の安全マークを使用しています。



注意：製品に損傷を与える危険性があります。



警告：人身事故につながる危険性があります。

感電、火災、UV放射に対する過度の露出、および人身事故を防ぐための一般的な情報については、以下の説明をお読みください。

警告：

火災の発生を防ぐためのヒント

1. VARI*LITE® 照明器具は、ランプを使用するように設計されています。ランプを交換する際は、ランプの種類（など）を確認するようにしてください。他の種類のランプを取り付けると危険です。
2. 照明器具は、本マニュアルの指示に従って操作するかぎり、どのようなタイプの表面にでも取り付けることができます。詳細については、本マニュアルを参照してください。
3. ヒューズを交換する場合は、同じヒューズ（同じ種類、同じクラス）を使用してください。
4. VARI*LITE® 照明器具は、可燃性物質または他の光源から必要な距離だけ離して配置してください。

警告：

感電を防ぐためのヒント

1. VARI*LITE® 照明器具は、乾燥した環境で使用するように設計されています。雨で濡れる場所や湿気の多い場所に取り付けると、照明器具が傷むことがあります。
2. VARI*LITE® 照明器具を修理点検する場合は、必ず先に電源を切ってください。
3. 照明器具の修理点検は、資格を持つ技師のみが行うようにしてください。

警告：

過度の UV 放射にさらされないためのヒント

1. VARI*LITE® 照明器具の多くは、UV 放射を生ずる HID タイプのランプを使用しています。ランプを直視することは避けてください。
2. レンズまたはシールドを使わずに照明器具を点灯すると危険です。レンズ、シールド、紫外線画面は、ひび割れや深い引っかき傷などにより、その効力が損なわれるようになったら取り替えるようにします。

警告：

人身事故を防ぐためのヒント

1. 照明器具が点灯しているときは、その外側が熱くなります。熱くなった器具やコンポーネントを取り扱う際には、適切な防具（手袋や保護用眼鏡）を使用してください。
2. 照明器具が点灯しているときは、そのランプが熱くなります。ランプを交換する場合は、照明器具の電源を切り、ランプの温度が下がるまで待ってください。ランプの裏ぶたをあけると、遮断スイッチが働いて、ランプの電源が切れる場合があります。
3. アーク灯は紫外線を放射します。この紫外線によって、ひどい火傷を負ったり、目の炎症を起こすことがあります。さらに、アーク灯は、高圧高温の状態で光を発します。そのため、万一アーク灯が破損すると、飛び散った破片で人身事故や火災が発生する危険性があります。
4. 再点灯するときには、保護用眼鏡を着用してください。
5. 損傷したランプを取り扱う場合は、適切な防具（手袋や保護用眼鏡）を着用してください。
6. 手袋を着用せずに直接手でランプを触った場合は、変性アルコールを使ってランプをきれいにし、糸くずの出ない布で拭いてから照明器具を取り付け、電源を入れるようにします。
7. 傷がついたランプや熱によって変形したランプは取り替えてください。

警告：

RF 干渉

1. 本製品は Class A に分類されます。本製品は、家庭環境において無線干渉を起こす可能性があります。その場合、使用者は適切な処置を取らなければならないことがあります。

アーク灯の特性

1. 停電後または大きな電圧ディップ後にアーク灯を再点灯する場合は、しばらく時間をおくようにしてください。Lamp Power-Up State) システム設定によっては、温度が下がったときに自動的に再点灯される場合があります。
2. アーク灯は点光源です。

Table of Contents

Introduction

About This Manual	1
Additional Documentation	1
Text Conventions	2
Customer Service	2

Chapter 1. Description

Features

Overview	4
----------------	---

Components

Included Items	5
Replacement Items/Accessories	5
VL2416 Wash Luminaire	6
LED Indicators	7

Chapter 2. Installation

Power and Data Cabling Requirements

Power	10
Current vs. Voltage	11
Data Cables	11
Recommended Cable Types/Manufacturers	12
Male Termination Connector	13
Loopback Connector	13

Installation Procedures

Installing Lamp	14
Hanging the Luminaire	15
Floor Mounting the Luminaire	18
Connecting Data and Power	18

Powering Up

Power-Up Procedure	19
Align Lamp for Flat Field	20
Set DMX Mode	21

Addressing

Program Starting Address	22
Program Starting Address Without Calibrating the Luminaire	22

Chapter 3. Operation

DMX Modes	
8-Bit and 16-Bit Modes.....	24
DMX Mapping	
Beam Control	25
Color Control	26
Luminaire Timing	
Luminaire Timing Channel Information.....	27
Control Channel Functions	35
Updating Software	
Reprogramming Luminaires	36
Components Overview	36
Reprogramming Procedure.....	37
Transferring Software From Luminaire to Luminaire	40

Chapter 4. Menu System

Operation	
What Is the Menu System?	44
Controls Operation	44
Display Orientation	45
Default State	46
Decimal Placement.....	46
Display Test.....	46
Shortcuts.....	47
Mapping	
Menu System Overview.....	48
Menu System Functions.....	49
Function Definitions	53
Cues and Sequences	
Overview	56
Storing	56
Playback	56
Hardware Requirements.....	56
Cue Operations.....	57
Self Tests	
Running Parameter Tests	60
Diagnostic Tests	62

Appendix A. Troubleshooting and Maintenance

Troubleshooting
Error Messages..... 70
Troubleshooting Guide..... 71

Routine Maintenance
Lamp Replacement 74
Front Glass Replacement 76
Cleaning Optical Lenses and Filters 78

Appendix B. Technical Specifications

Mechanical..... 79
Optical..... 79
Operational..... 80
Photometric 80

Notes

Introduction

About This Manual

This manual provides necessary information regarding safety, installation, operation and routine maintenance for the VARI*LITE® VL2416™ Wash Luminaire. Familiarizing yourself with this information will help you to get the most out of your product.



WARNING: It is important to read ALL accompanying safety and installation instructions to avoid damage to the product and potential injury to yourself or others.

This manual covers the following models:

Model	Part Number	Source
VL2416™ Wash Luminaire	20.9661.0001.06	Arc

Additional Documentation

A service manual for extended maintenance of the VL2400 Series Wash Luminaire is available in both printed and electronic (PDF) formats:

- VL2400 Series Wash Luminaire Service Manual (02.9661.0010)
- Testing, Troubleshooting, Component Replacement and Illustrated Parts Breakdown.

Note: Performing maintenance procedures may void the product warranty. Refer to the Vari-Lite Limited Warranty card included in the product shipping package for more information.

For more information regarding DMX512 systems, refer to the following document available from United States Institute for Theatre Technology, Inc. (USITT):

- Digital Data Transmission Standard for Dimmers & Controllers plus AMX 192 Analog Multiplex Data Transmission Standard for Dimmers & Controllers. (A copy of Recommended Practice for DMX512 is included.)

USITT Inc.
10 West 19th St. / Suite 5A
New York, NY 10011-4206 USA
Tel: (212) 924 - 9088 Fax: (212) 924 - 9343 / www.usitt.org

Text Conventions

The following styles and meanings are used throughout this manual:

Style	Meaning
[Button]	Front panel button. Example: Press [Menu].
[Up] / [Down] arrows	Press either [Up] or [Down] arrow button at Menu Display.
MENU	LCD Menu Display read-out. Example: Press [Up] / [Down] arrows until LAMP appears.

Customer Service

Our Goal

At Vari-Lite, we are committed to providing you the highest quality in customer service. Our comprehensive resources are available to help your business succeed and ensure you get the full benefit of being a Vari-Lite customer. Whether your needs are telephone troubleshooting assistance, product training or technical service, our full-time staff of experienced professionals are on-hand to provide support.

How to Reach Us

For assistance in your area, call the dealer from which your product was purchased.

or

Contact an Authorized Service Center.

or

Contact the Vari-Lite Customer Service Department, 9am -6pm CST Monday through Friday, at the following:

phone: 1-877-VARI-LITE (1-877-827-4548)

email: customerservice@vari-lite.com

Additional Resources

For additional resources and documentation, please visit our website at www.vari-lite.com and follow the Support link.



CHAPTER 1.

Description

This chapter contains descriptions of luminaire features and components, along with a list of accessories which are available.

- **Features**
- **Components**

Features

Overview

The VL2416 wash luminaire contains the following standard features:

- DICHRO*TUNE™ radial color changer which employs enhanced dichroic color filters to produce smooth, full spectrum color crossfades. The mechanism allows independent blue, amber, and magenta color control.
- An internal mechanical douser which provides intensity control and strobing.
- Zoomable beam spreader mechanism which provides 5° to 55° field in less than 1.2 seconds.
- 1200 watt arc source.
- An upper enclosure that houses the control electronics as well as a power factor corrected arc power supply.
- Control by DMX512 protocol.
- Two truss hook brackets for versatile hanging configurations.

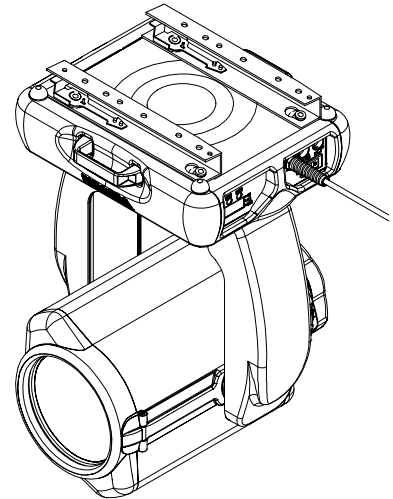

Components

Included Items

The following illustration shows all items included with the luminaire:

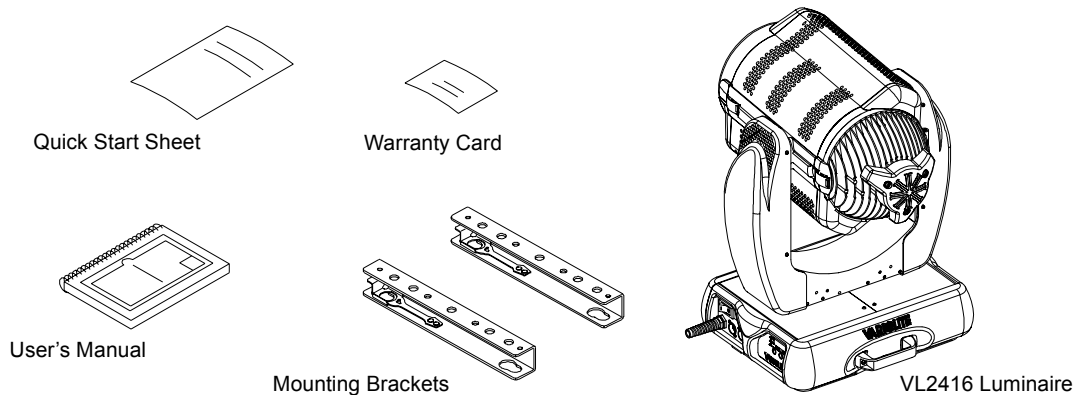

Figure 1-1: VL2416 Luminaire Packing List

Replacement Items/Accessories

The following optional and/or replacement items can be ordered directly from Vari-Lite. (Please order by Vari-Lite part number.)

Vari-Lite Part No.	Accessory
20.9625.0132	Road Case, Plastic (two hole)
22.9620.0194	Safety Cable Assembly
23.9623.0177	DMX Termination Male Connector Assembly
25.9661.0056	Loopback Connector Assembly
28.9661.054	Luminaire Programming (XLR5) Kit
55.6841.0001	Mega Claw Truss Hook, 2" Round
55.6840.0001	Mega Clamp Truss Hook, Round and Square
42.5002.0004	Clear Front Glass
42.5002.0005*	Stipple Front Glass
42.5002.0006	Medium Flood / 8-Row Lenticular Front Glass
42.5002.0007	Medium Flood / 10-Row Lenticular Front Glass
42.5002.0008	Medium Flood / 12-Row Lenticular Front Glass
42.5002.0009	Very Wide Flood / Buxom Front Glass

* Factory standard front glass.

VL2416 Wash Luminaire

The following illustration shows the major luminaire components and controls.

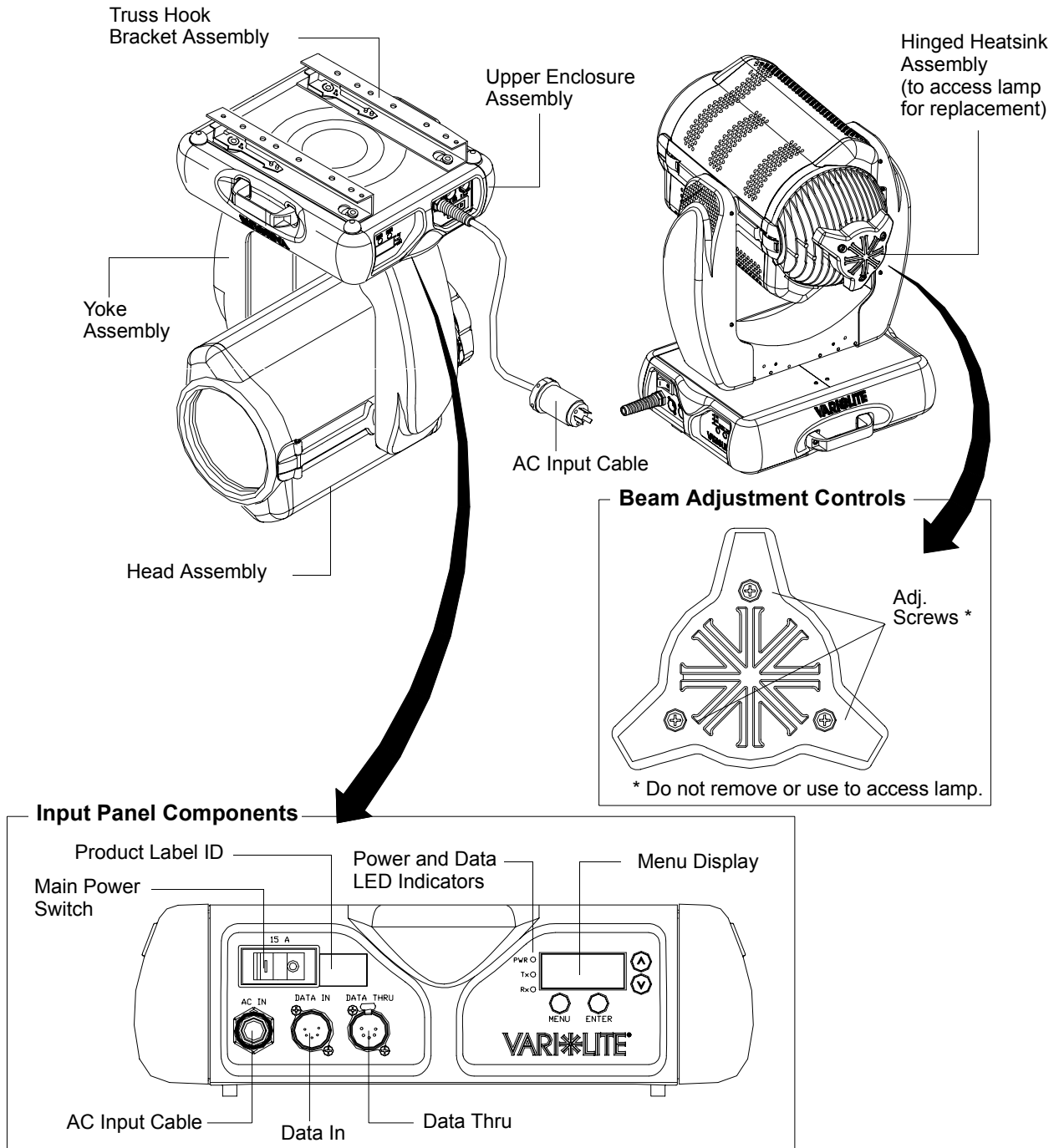

Figure 1-2: Luminaire Overview

LED Indicators

The LED indicators report the status of power and data to the luminaire.

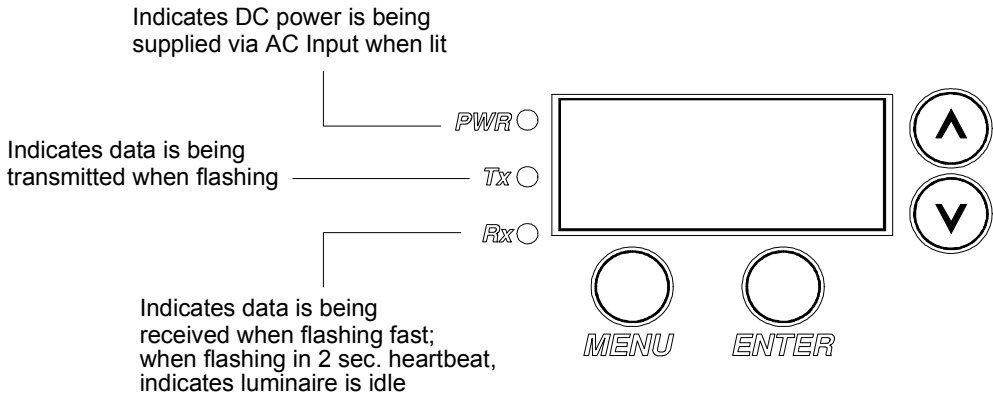

Figure 1-3: LED Indicators Overview

Notes



CHAPTER 2.

Installation

This chapter contains instructions for installation of the luminaire. It includes connecting power and data, along with instructions for powering up the luminaire for the first time and addressing it within your system.

- **Power and Data Cabling Requirements**
- **Installation Procedures**
- **Powering Up**
- **Addressing**

Power and Data Cabling Requirements

Power

The luminaire requires standard AC power distribution from 200-240 VAC, 50/60 Hz. Five amps to twelve amps will be required.

Depending on the application, the luminaire's AC input cable may require a different connector. If required, install a new connector meeting your requirements using the following wire color code reference:

Wire*	Connection
Green/Yellow	AC Ground
Blue	AC Neutral
Brown	AC Line

* International (Harmonized) Standard



WARNING: DO NOT connect to three-phase Delta service in countries with 240 volt power.

Note: The lamp will not strike below 180 volts RMS.

For single-phase power at 200-240 volts RMS:

Connection	Pin
AC Neutral	X
AC Line	Y
Ground (Earth)	G

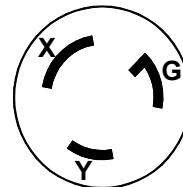

For three-phase power at 208 volts RMS:

Connection	Pin
Phase 1	X
Phase 2	Y
Ground (Earth)	G

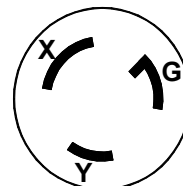

Current vs. Voltage

The following table provides the luminaire’s current draw at specific voltages. Current is calculated with the lamp on and all motors sequencing.

Voltage	Current
180.0	8.2
190.0	7.8
200.0	7.4
210.0	7.0
220.0	6.6
230.0	6.3
240.0	6.0
250.0	5.8

Data Cables

The luminaire is equipped with two, 5-pin XLR connectors for DATA IN and DATA THRU (out) applications. DATA IN requires a 5-pin, female XLR connector and DATA THRU requires a 5-pin, male XLR connector. When purchasing or constructing data cables, it is important that not only the correct cable type be used, but also quality cable to ensure a reliable DMX512 system. Your cabling should meet the following USITT DMX specification requirements:

- Suitable for use with EIA485 (RS485) operation at 250k baud.
- Characteristic impedance 85-150 ohms, nominally 120 ohms.
- Low capacitance.
- Two twisted pairs.
- Foil and braid shielded.
- 24 AWG min. gauge for runs up to 1000 feet (300m).
- 22 AWG min. gauge for runs up to 1640 feet (500m).

Note: Microphone type cables and other general purpose, two-core audio or signal cables are not suitable for use with DMX512.

Refer to the USITT Recommended Practice for DMX512 guide for additional information regarding DMX512 systems. How to obtain a copy is detailed in [“Additional Documentation” on page 1.](#)

The XLR 5-pin connectors should be wired as follows:

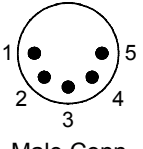
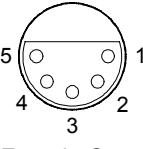
Pin/Wire Code to XLR Connectors						
Data Thru Cable Pinout  Male Conn	Pin 1 Foil & Braided Shield	Pin 2 1st conductor of 1st twisted pair Data (-)	Pin 3 2nd conductor of 1st twisted pair Data (+)	Pin 4 1st conductor of 2nd twisted pair Data (-)	Pin 5 2nd conductor of 2nd twisted pair Data (+)	Data In Cable Pinout  Female Conn

Recommended Cable Types/Manufacturers

These are only a few of the suitable cable types. Any quality EIA485, twisted pair, 120 ohm, shielded cable will also work.

Table 2-1: Recommended Cable Types

Type	Pairs	ZΩ*	Jacket	AWG	Use	Temp (F)
Belden Cables						
1215A	2	150	PVC	26	IBM Type 6 Office cable	75
1269A	2	100	PTFE	22 (Solid)	High Temp, Plenum cable	200
8102	2	100	PVC	24	UL2919	80
8132	2	120	PVC	28	UL2919	80
8162	2	100	PVC	24	UL2493	60
82729	2	100	PTFE	24	High Temp, Plenum cable	200
88102	2	100	PTFE	24	High Temp, Plenum cable	200
89696	2	100	PTFE	22	High Temp, Plenum cable	200
89729	2	100	PTFE	24	High Temp, Plenum cable	200
89855	2	100	PTFE	22	High Temp, Plenum cable	200
9729	2	100	PVC	24	UL2493	60
9804	2	100	PVC	28	UL2960	60
9829	2	100	PVC	24	UL2919	80
9842	2	120	PVC	24	UL2919	80
Proprex Cables						
PC224P	2	110	Polyurethane	22	Heavy Duty and Portable	105
PC224T	2	110	PVC	22	UL2464	105
PC226T	3	110	PVC	22	UL2464	

* Characteristic Impedance

Male Termination Connector

A male XLR termination connector is required at the last luminaire (or "far end of the line") to prevent signal reflections. Signal reflections may cancel out the signal at certain line lengths, resulting in errors. The terminator is also necessary for software downloads and running tests on multiple luminaires. To construct your own connector, you will need the following components:

- 5-pin, male XLR connector.
- Two 1/4W 5% 120 ohm resistors.

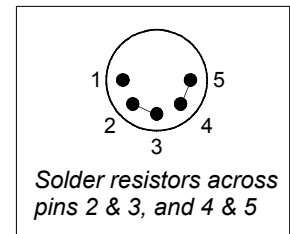

Note: A male termination connector is also available as an accessory from Vari-Lite. See [“Replacement Items/Accessories” on page 5.](#)

Loopback Connector

When transferring software versions from luminaire to luminaire, a loopback connector is required at the first luminaire in the data link.

To construct your own connector, you will need the following components:

- 5-pin, female XLR connector.
- Two small segments of 22AWG wire.

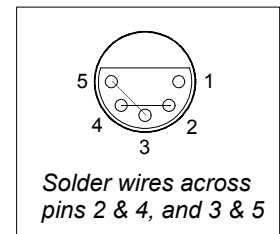

Note: A loopback connector is available as an accessory from Vari-Lite. See [“Replacement Items/Accessories” on page 5.](#)

Installation Procedures

Installing Lamp

In the event the lamp was packed separately during shipment, it will be necessary to install in the luminaire before use.



WARNING: Ensure that power is removed from luminaire when installing lamp.



CAUTION: Wear cotton gloves or other covering while installing lamp. Touching lamp glass with bare fingers will leave oil and may cause the lamp to explode or reduce lamp life. If touched, use alcohol and cotton cloth to thoroughly clean glass portion of lamp.

To install lamp:

- Step 1. Ensure power is removed from luminaire.
- Step 2. Remove lamp from shipping box.
- Step 3. At backcap assembly open latch and swing open.

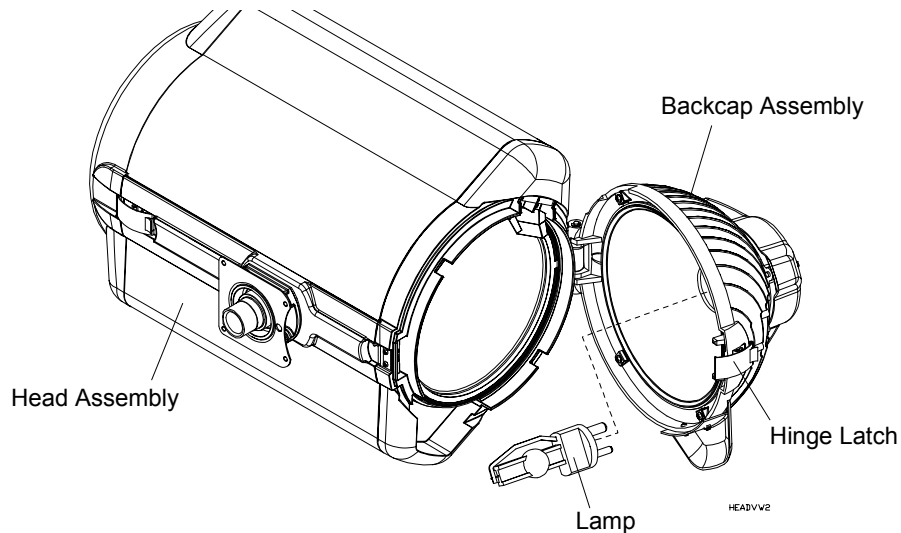

Figure 2-1: Installing/Replacing Lamp

- Step 4. Install lamp by pressing firmly into socket. Ensure lamp is fully seated in socket with base of lamp against socket base.
- Step 5. Close and latch backcap assembly.

Note: After installing a new lamp, it is necessary to adjust beam for optimum performance. This procedure is covered in [“Power-Up Procedure” on page 19.](#)

Hanging the Luminaire

The VL2416 wash luminaire can be hung horizontally or vertically from any structure designed to work with the type of load created by this moving luminaire. Two mounting bracket assemblies (provided) are used to attach truss hooks or other mounting hardware as required. Many compatible truss hooks are available from different manufacturers for your particular needs.

A minimum of one hook per truss hook bracket is required. If mounting method does not use truss hooks, two attachment points per truss hook bracket are required. When attaching more than one point on a single bracket, the attach points must be spaced as far apart as possible using the supplied mounting holes.

Install mounting hardware and brackets:

Step 1. Install truss hooks on two provided truss hook brackets as required.

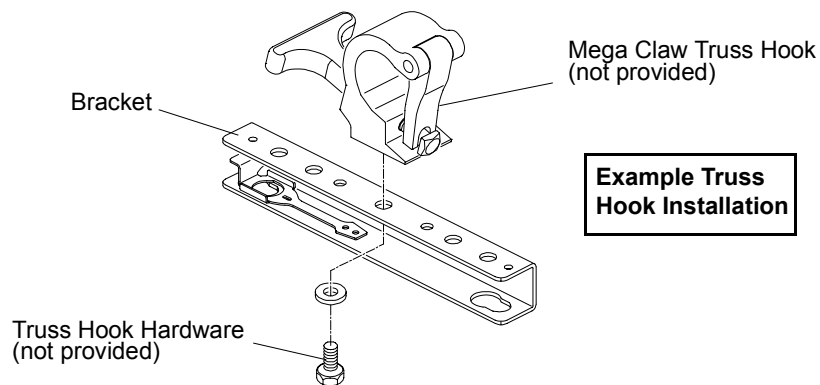

Figure 2-2: Installing Truss Hooks

Note: Various types of truss hooks can be used. The Mega Claw truss hook (as shown in the example above) as well as many other standard hooks, can be ordered separately.

Step 2. Determine required configuration of bracket installation. Brackets may be installed in either orientation as shown.

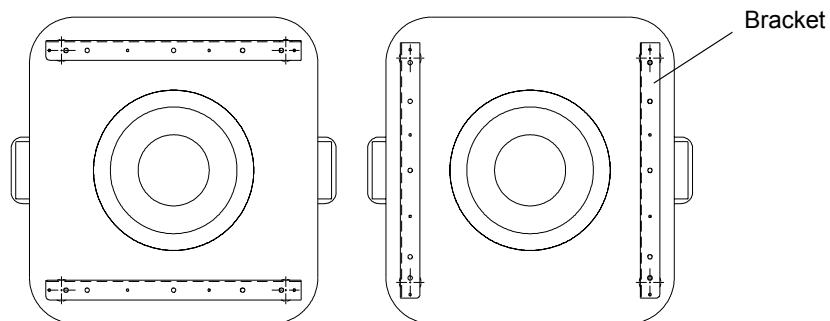

Figure 2-3: Bracket Orientation Options

Step 3. While pulling up on locking mechanism release, fit keyed holes onto raised mounting buttons at bottom of enclosure. Slide forward and release locking mechanism to lock in place. Ensure brackets are locked securely. (Always face brackets in same direction as shown.)



WARNING: Ensure that the bracket locking mechanism is fully seated after the bracket is installed on the luminaire.

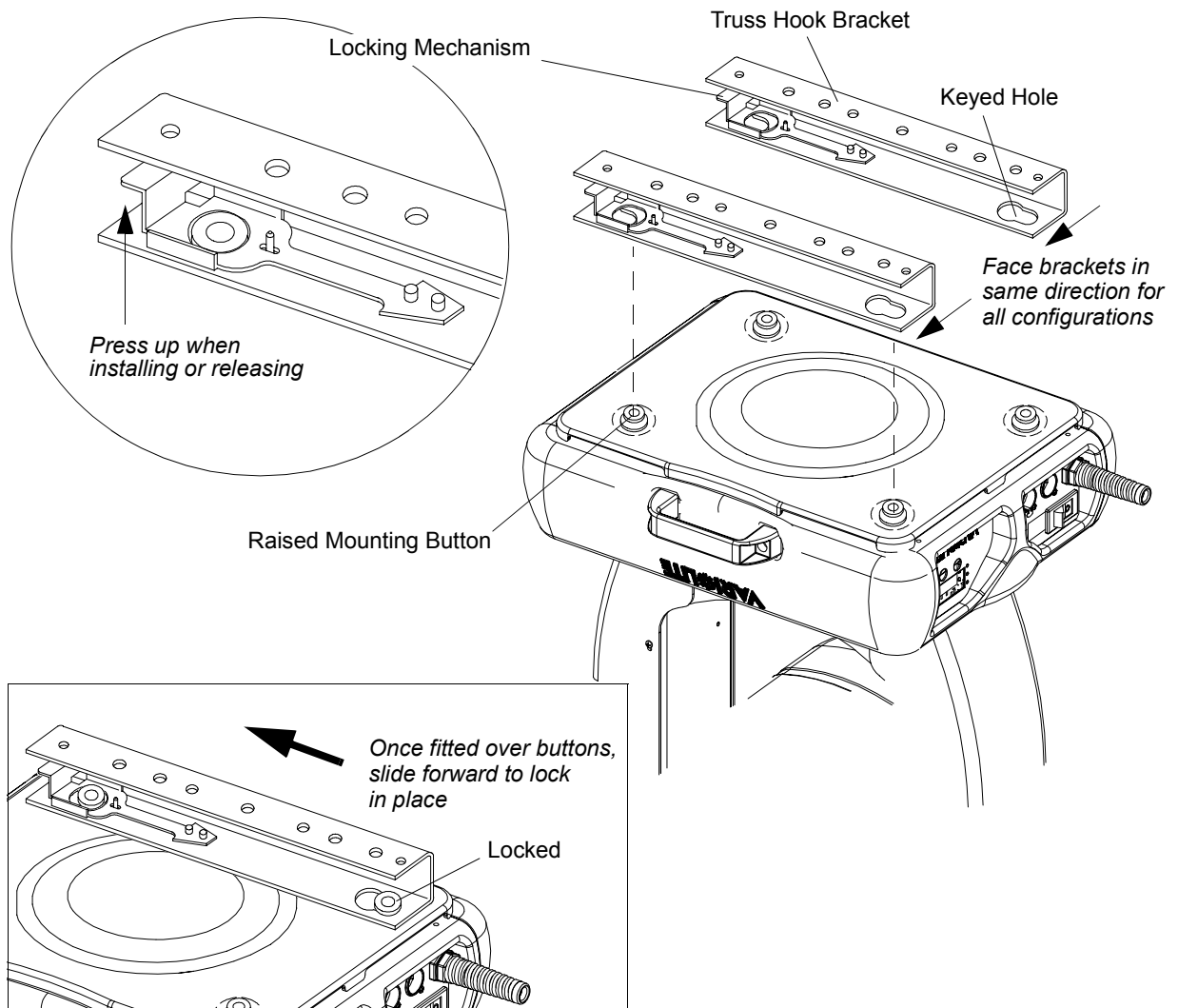

Figure 2-4: Installing Brackets on Luminaire Enclosure

Installing in Truss:

- Step 1. Using two people, lift luminaire into mounting position.
- Step 2. Secure in place with truss hook. Ensure truss hook hardware that locks hook in place (e.g. wing bolt) is properly tightened and that luminaire is fully supported.
- Step 3. Attach safety cable (as required) as follows:
 - a. Connect one end of cable to luminaire handle.
 - b. Loop at least once around truss/pipe and attach other end of cable to other handle.
- Step 4. Connect power and data cables according to procedure given in [“Connecting Data and Power”](#) on page 18.

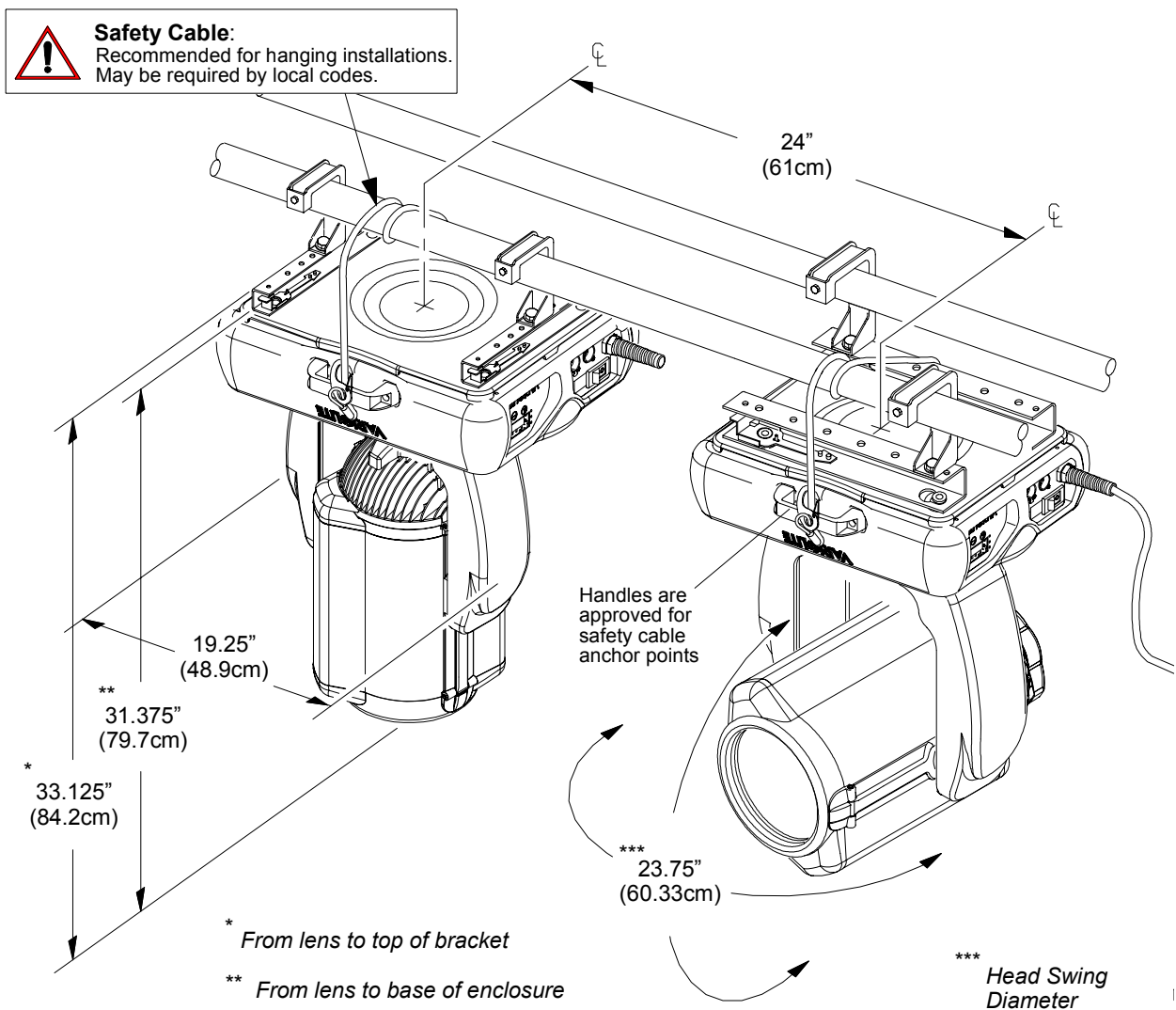

Figure 2-5: Hanging Configuration and Dimensions

Floor Mounting the Luminaire

The luminaire enclosure is sufficient to stabilize the luminaire in a floor installation, provided that the mounting surface is flat and sturdy.

Connecting Data and Power

A maximum of 32 luminaires may be connected in any one DMX data link.

Note: This maximum limit applies to the luminaire "daisy chain" only. Your system or console may require fewer luminaires on a single data link path. Consult your console documentation for more information.

To connect power and data:

- Step 1. Connect data cable from console to first luminaire in chain at DATA IN connector.
- Step 2. If required, connect additional data cables from DATA THRU connectors to DATA IN connectors of remaining luminaires in link.
- Step 3. At last luminaire in link, install male termination connector at DATA THRU connector. (Luminaires and other devices on the same DMX chain may not function properly without termination.)

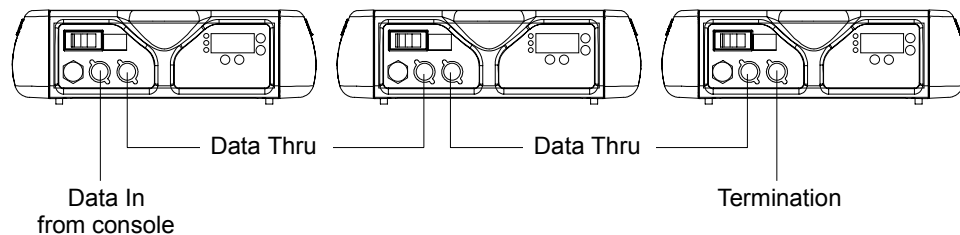

Figure 2-6: Data Link

- Step 4. Connect AC Input Cable connector to power input source.
- Step 5. Dress AC input and data cables and secure them so that they will not interfere with luminaire head and yoke movement.

Powering Up

Power-Up Procedure

Since Lamp On is the default state, the lamp will strike when the luminaire is powered up for the first time. When AC power is applied, the luminaire will immediately begin a calibration sequence that steps it through full pan and tilt movements. The internal color, gobo, and beam mechanisms will also move through a full range of motion. After calibration, the luminaire head will either stop at its "home" position (which positions the pan axis at mid-rotation and the head parallel to the yoke with the lens pointing away from the luminaire upper enclosure) or move to its current DMX-defined position if DMX data is present. All internal mechanisms also move to their "home" or DMX-defined positions.

For arc lamp models, depending on the luminaire's setting for Lamp Power-Up State (refer to "[Menu System Functions](#)" on page 49), when power is applied, the arc lamp will either **a**) "strike" or ignite - Lamp On (*default*), **b**) await calibration and then strike - Cal On, or **c**) await manual command to strike - Lamp Off. (This does not apply to incandescent models. Incandescent lamps will only have intensity when commanded to do so.)



CAUTION: Before applying power, be sure the luminaire is hung or positioned so that the head and yoke can move freely without restriction.

To power up:

- Step 1. At each luminaire, apply power by switching power switch to "I" (ON) position. Luminaire will automatically step through following procedure:
- a. If Arc Lamp Power-Up State is set to Lamp On, lamp will strike (ignite).
 - b. Luminaire will cycle through calibration and stop at "home" position.
 - c. If Arc Lamp Power-Up State is set to Cal On, lamp will strike (ignite) at end of calibration sequence.

Align Lamp for Flat Field

After a new lamp is installed, it will be necessary to align the lamp to optimize the beam. Screws located at the luminaire's backcap will allow adjustment.



WARNING: Backcap and adjustment screws will be HOT during lamp operation. Wear gloves and/or use tools to prevent burns.

To align lamp for flat field:

- Step 1. Using internal menus select **Lamp** test to set beam. See [“Menu System” chapter on page 43](#) for more information. (If using console, set intensity to 100% and adjust diffusion to produce a tight beam.)
- Step 2. Position beam on a white wall at a distance of 10' to 20'.
- Step 3. Using three adjustment screws, adjust hot spot to center of beam.

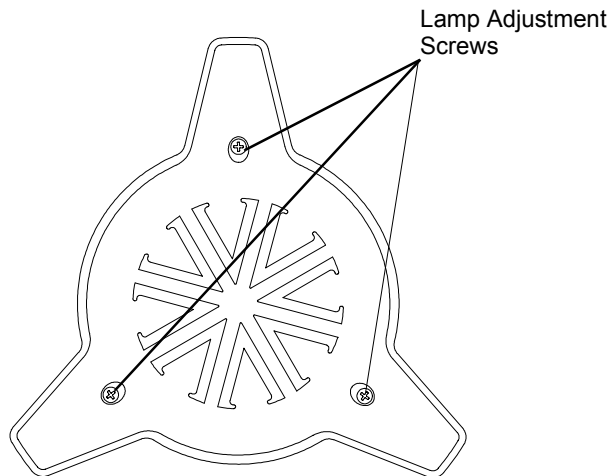

Figure 2-7: Lamp Adjustment Controls

Set DMX Mode

The VL2000 Series luminaires provide four modes for DMX operation. The mode is set using the luminaire's Menu Display.

- **8-bit Standard** - provides one 8-bit DMX channel for control of each luminaire function.
- **8-bit Enhanced** - provides additional channels for timing control.
- **16-bit Standard** - provides 16-bit control for pan/tilt.
- **16-bit Enhanced (default)** - provides 16-bit control for pan/tilt and additional channels for timing control.

To set the mode:

Step 1. Press [Menu].

Step 2. Press [Up] or [Down] button until DMX appears. Press [Enter].

Step 3. Press [Up] or [Down] to until desired mode is reached (8, 16, E 8, or E 16). Press [Enter] to set mode.

See [“DMX Modes” on page 24](#) for more information.

Note: Which mode is used may also be determined by the profile available in the DMX control console. For best control, response, smoothest movement and transitions, the 16-bit Enhanced mode is recommended. The 8-bit modes are supported for older style consoles with a limited number of DMX channels available, and if profiles are not supported. The 16-bit mode is supported for DMX consoles that do not provide access to the timing channels through either their architecture or their profiles. For more information see [“Luminaire Timing Channel Information” on page 27](#).

Addressing

Program Starting Address

The address setting for DMX console or Virtuoso console controlled systems is entered using the Menu Display. (Refer to “[Menu System](#)” chapter on page 43 for detailed instructions.)

The luminaire retains the DMX and Virtuoso addresses that are stored even if power is removed.

Note: Refer to your console operating instructions for specific information regarding its addressing requirements.

Program a DMX or Virtuoso starting address:

- Step 1. Press [Menu].
 - Step 2. Press [Up] / [Down] arrows until ADDR (Address) appears. Press [Enter].
 - Step 3. Press [Up] / [Down] arrows to access DMX (DMX console control) or VIRT (Virtuoso console control). Press [Enter].
 - Step 4. Press [Up] / [Down] arrows to enter starting address.
 - Step 5. Press [Enter] to set.
-

Program Starting Address Without Calibrating the Luminaire

It is possible to bypass the calibration sequence and go directly to the Menu Display programming in order to pre-program an address setting.

Program starting address without calibrating luminaire:

- While powering up luminaire, press and hold [Menu]. Program address as in [Program Starting Address](#) above.
-

Note: The luminaire will require a reset to restore control.



CHAPTER 3.

Operation

This chapter contains instructions for operating the luminaire using DMX control and for updating the internal software.

- **DMX Modes**
- **DMX Mapping**
- **Luminaire Timing**
- **Updating Software**

DMX Modes

8-Bit and 16-Bit Modes

These tables assume a DMX start address of 1. When a different starting address is used, this address becomes channel 1 function and other functions follow in sequence.

Standard 8-Bit (8)

Function	DMX Channel
Intensity	1
Pan	2
Tilt	3
Blue	4
Amber	5
Magenta	6
Beam	7
Strobe	8
Rotating Lens	9
Control	10

Standard 16-Bit (16)

Function	DMX Channel
Intensity	1
Pan	2 - 3
Tilt	4 - 5
Blue	6
Amber	7
Magenta	8
Beam	9
Strobe	10
Rotating Lens	11
Control	12

Enhanced 8-Bit (E 8)

Function	DMX Channel
Intensity	1
Pan	2
Tilt	3
Blue	4
Amber	5
Magenta	6
Beam	7
Strobe	8
Rotating Lens	9
Focus Timing	10
Color Timing	11
Beam Timing	12
Control	13

Enhanced 16-Bit (E 16) - Default

Function	DMX Channel
Intensity	1
Pan	2 - 3
Tilt	4 - 5
Blue	6
Amber	7
Magenta	8
Beam	9
Strobe	10
Rotating Lens	11
Focus Timing	12
Color Timing	13
Beam Timing	14
Control	15

DMX Mapping

Beam Control

Beam

Table 3-1: DMX Map for Beam

% Value	DMX Value	Action
0	0	Narrow
100	255	Wide

Strobe

Table 3-2: DMX Map for Strobe

% Value	DMX Value	Action
0	0-2	Open
1	3-5	Closed
2	6-7	Slow Random
3	8-10	Med Random
4	11-12	Fast Random
5-100	13-255	Speed Range

Rotating Lens

Table 3-3: DMX Map for Rotating Lens

% Value	DMX (0-255)	Wheel Position
0-84	0-215	Index Position
85	216	Fast Spin CW
86-90	217-232	Variable Rates
91	233	Slow Spin CW
92	234-237	Stop
93	238	Slow Spin CCW
94-99	239-254	Variable Rates
100	255	Fast Spin CCW

Color Control

Blue

Table 3-4: DMX Map for Blue

% Value	DMX Value	Action
0	0	Open
100	255	Closed

Amber

Table 3-5: DMX Map for Amber

% Value	DMX Value	Action
0	0	Open
100	255	Closed

Magenta

Table 3-6: DMX Map for Magenta

% Value	DMX Value	Action
0	0	Open
100	255	Closed

Luminaire Timing

Luminaire Timing Channel Information

Timing channel control improves the timed moves of certain groups of parameters. We provide three timing channels, one for Focus (Pan and Tilt), one for color parameters and one for beam parameters. Timing channels support time values of up to six minutes.

Table 3-7: Channel Function / Timing Channel Relationship

Channel Function	Timing Channel		
	Focus Time	Color Time	Beam Time
Pan (Hi Byte/Lo Byte)	◆		
Tilt (Hi Byte/Lo Byte)	◆		
Blue		◆	
Amber		◆	
Magenta		◆	
Beam			◆
Rotating Lens			◆

A timing value of zero is full speed. A time value of 100% (or 255 in DMX) causes the associated parameter(s) to follow cue fade time (console time) rather than the timing channel.

Note: The particular storing syntax for your console, as well as instructions on how to write part cues, can be found in the operation manual for that console.

To use these channels, you must:

- Step 1. Create the cue, including color, gobo, edge and diffusion as required.
- Step 2. Decide which fixtures and which parameter groups will use timing channels.
- Step 3. Assign a value to the particular timing channel(s) you wish to use (for timing information see chart on next page).
- Step 4. Set console timing (or cue fade time) for parameters and timing channels to zero seconds.
- Step 5. Store cue.

Note: Avoid changing timing channel values in a fading cue. This can cause unexpected behavior in the luminaire as the timing channel value is updated over time. Timing channel values and the final destination of the parameters affected by the timing channel should always be sent in a zero count.

Timing channels can be set in either % or 0-255 (DMX) modes, with the following values assigned:

Table 3-8: Timing Channels Map

% Value	DMX	= Seconds
	0	Full Speed
	1	0.2
	2	0.4
1	3	0.6
	4	0.8
2	5	1
	6	1.2
	7	1.4
3	8	1.6
	9	1.8
4	10	2
	11	2.2
	12	2.4
5	13	2.6
	14	2.8
6	15	3
	16	3.2
	17	3.4
7	18	3.6
	19	3.8
8	20	4
	21	4.2
	22	4.4
9	23	4.6
	24	4.8
10	25	5
	26	5.2
	27	5.4
11	28	5.6
	29	5.8
	30	6
12	31	6.2
	32	6.4
13	33	6.6

Table 3-8: Timing Channels Map (Continued)

% Value	DMX	= Seconds
	34	6.8
	35	7.0
14	36	7.2
	37	7.4
15	38	7.6
	39	7.8
	40	8
16	41	8.2
	42	8.4
17	43	8.6
	44	8.8
	45	9
18	46	9.2
	47	9.4
19	48	9.6
	49	9.8
	50	10
20	51	10.2
	52	10.4
	53	10.6
21	54	11
	55	11
22	56	12
	57	12
	58	13
23	59	13
	60	14
24	61	14
	62	14
	63	15
25	64	15
	65	16
26	66	16
	67	16
	68	17
27	69	17
	70	18
28	71	18
	72	18
	73	19
29	74	19
	75	20

Table 3-8: Timing Channels Map (Continued)

% Value	DMX	= Seconds
30	76	20
	77	20
	78	21
31	79	21
	80	21
	81	22
32	82	22
	83	23
33	84	23
	85	23
	86	24
34	87	24
	88	25
35	89	25
	90	25
	91	26
36	92	26
	93	27
37	94	27
	95	27
	96	28
38	97	28
	98	29
39	99	29
	100	29
	101	30
40	102	30
	103	30
	104	31
41	105	31
	106	32
42	107	32
	108	32
	109	33
43	110	33
	111	34
44	112	34
	113	34
	114	35
45	115	35
	116	36
46	117	36

Table 3-8: Timing Channels Map (Continued)

% Value	DMX	= Seconds
	118	36
	119	37
47	120	37
	121	38
48	122	38
	123	38
	124	39
49	125	39
	126	39
	127	40
50	128	40
	129	41
51	130	41
	131	41
	132	42
52	133	42
	134	43
53	135	43
	136	43
	137	44
54	138	44
	139	45
55	140	45
	141	45
	142	46
56	143	46
	144	47
57	145	47
	146	47
	147	48
58	148	48
	149	49
59	150	49
	151	49
	152	50
60	153	50
	154	50
	155	51
61	156	51
	157	52
62	158	52
	159	52

Table 3-8: Timing Channels Map (Continued)

% Value	DMX	= Seconds
	160	53
63	161	53
	162	54
64	163	54
	164	54
	165	55
65	166	55
	167	56
66	168	56
	169	56
	170	57
67	171	57
	172	58
68	173	58
	174	58
	175	59
69	176	59
	177	59
	178	60
70	179	60
	180	65
71	181	65
	182	65
	183	70
72	184	70
	185	75
73	186	75
	187	75
	188	80
74	189	80
	190	85
75	191	85
	192	85
	193	90
76	194	90
	195	95
77	196	95
	197	95
	198	100
78	199	100
	200	110
79	201	110

Table 3-8: Timing Channels Map (Continued)

% Value	DMX	= Seconds
	202	110
	203	120
80	204	120
	205	120
81	206	130
	207	130
	208	140
82	209	140
	210	140
	211	150
83	212	150
	213	160
84	214	160
	215	160
	216	170
85	217	170
	218	180
86	219	180
	220	180
	221	190
87	222	190
	223	200
88	224	200
	225	200
	226	210
89	227	210
	228	210
	229	220
90	230	220
	231	230
91	232	230
	233	230
	234	240
92	235	240
	236	250
93	237	250
	238	250
	239	260
94	240	260
	241	270
95	242	270
	243	270

Table 3-8: Timing Channels Map (Continued)

% Value	DMX	= Seconds
	244	280
96	245	280
	246	290
97	247	290
	248	290
	249	300
98	250	300
	251	310
99	252	310
	253	310
	254	310
100	255	Follows Cue Data

Control Channel Functions

The following control actions must be accomplished with zero time transition or with timing disabled. Discrete values must be used and not manual controls such as faders or encoders.

Table 3-9: Control Channel Functions

Control Channel Function	Control Channel Value		
	% Value	For 3 Secs or Greater	After 3 Secs
Display On	1	1-4	0
Luminaire Reset	33	81 - 87	0
Lamp Off	66	165 - 171	0
Lamp On	99	249 - 255	0

To use control channel functions:

- Step 1. Select an action to be sent.
- Step 2. Set control channel value for desired action (for example, 84 for reset). Hold value for 3 seconds.
- Step 3. Set control channel value to zero. (This must occur without any scaling values. Action will be voided if other values are detected between action value and zero.)

Note: A numerical keypad is required for sending values. An encoder or fader does not allow for a “snap” value change, which is required to affect the control functions.

Updating Software

Reprogramming Luminaires

In some cases, it may be desirable to upgrade the luminaire's operating software. This process requires a PC, *VLDownload.exe*, .bin files and the Luminaire Programming Kit (28.9661.0054).

Components Overview

Computer Requirements

- PC running Windows 95/98, Windows NT (4.0 or higher), or Windows 2000. (Program is not compatible with Macintosh computers.)
- Serial communication port. (RS-232 only, USB not supported.)

VL Download Program

The *VL Download.exe* program allows you to transfer new versions of the operating software (.bin files) to the luminaires via the PC. The *VL Download.exe* and current .bin files are available from the Product Downloads page at www.vari-lite.com. Instructions for installing the program on your PC are also available on the Product Downloads page.

Luminaire Programming Kit

The luminaire programming kit allows you to connect your PC to the luminaire chain in order to update software.

Luminaire Programming Kit (28.9661.0054) components:

- 6-Ft. Serial Straight Thru DB9M-F Cable (46.6033.0006)
- RS-232 to RS-485 Interface Converter (46.6036.0001)
- 6-Ft. RJ45 to 5-Pin Female XLR Cable (25.9661.0055)

Reprogramming Procedure

Note: Up to 32 luminaires can be programmed at the same time if they are data linked together. Refer to “[Connecting Data and Power](#)” on page 18. (Programming more than 32 luminaires will require programming in batches of 32 or less.)

To update luminaire software:

- Step 1. From Product Downloads page at www.vari-lite.com, download and install the *VLDownload.exe* program and required .bin files onto your PC (following instructions at the website).
- Step 2. Assemble Luminaire Programming Kit components by connecting *Serial Straight Thru Cable* and *RJ45-to-XLR cable* to Interface Converter.

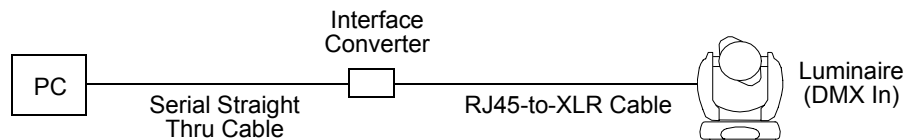

Figure 3-1: Hardware Setup

- Step 3. Connect *Serial Straight Thru cable* to serial Comm Port of PC and connect *RJ45-to-XLR cable* to DMX In connector of luminaire.
- Step 4. Apply power to PC and luminaire(s).
- Step 5. Run *VLDownload.exe* program by selecting from Start menu Programs list or by selecting from C:\ProgramFiles\Vari-Lite\VLDDownload Program directory. (Luminaire Software Download window will open.)
- Step 6. At **Select Comm Port** section of window (refer to [Figure 3-2](#) on next page), select serial Comm Port (Comm Port 1, Comm Port 2, Comm Port 3, or Comm Port 4) where *Serial Straight Thru Cable* is connected.

Note: DMX Data must be disconnected before downloading software to luminaires. (Do not merge with DMX signal.)

- Step 7. At **Select Software to Download** section of window, select required luminaire software version to download by clicking its button or select **Download All**. (Software version is identified by the date and time: MM/DD/YY and HH:MM.) The buttons function as follows:

VL241x button downloads the software to all VL2400 series luminaires.

Download All button is the equivalent of executing all of the specific software version buttons shown in the window (if applicable). They will be executed one at a time in the order they appear in the window. This button can be used when any combination of VARI*LITE luminaires are connected to the PC.

Note: Version dates shown in this graphic are for illustration purposes only and may not correspond to the version you are downloading.

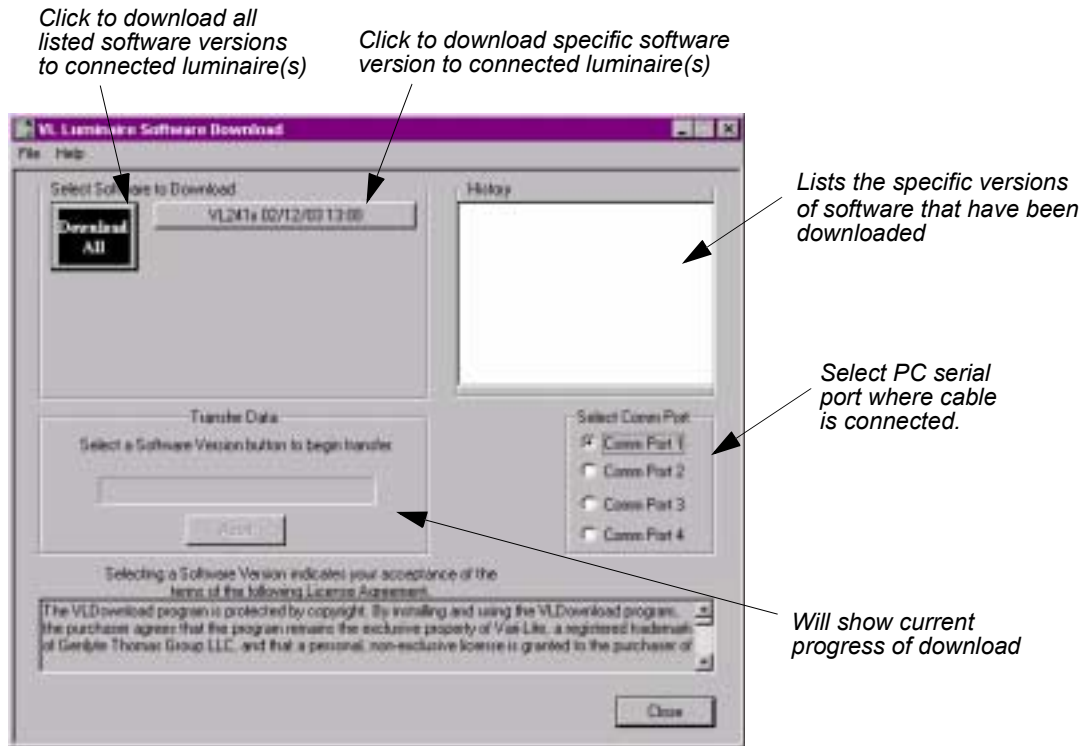

Figure 3-2: Download Interface Window

Step 8. Download will proceed. One of the following will occur:

- Correct** ➡ Luminaire's green Rx LED will blink rapidly and its menu will display number of blocks received (this number will vary depending on software version being downloaded). This indicates that data is being sent from PC to luminaire. However, if display does not show blocks as they are received, this indicates that the version being downloaded matches the one already installed or that the luminaire type does not match.
- Trouble** ➡ If luminaire's green Rx LED does not blink rapidly and its menu does not display blocks, this indicates that no data is being received. (Check cable connections, port selection, etc. and try again.)

Step 9. Click Close to exit.

Note: The History section of the window shows what specific types of luminaire software have been downloaded since the beginning of the session (window will reset once the program is closed and re-opened).

Verify software version at luminaire:

- Step 1. At Menu Display, press [Menu].
- Step 2. Press [Up] / [Down] arrows until **Fixt** appears. Press [Enter].
- Step 3. Press [Up] / [Down] arrows until **Ver** appears. Press [Enter].

The first half of the version date will be displayed as MM/DD/YY (month/day/year): For example, 07/21/02 = July 21, 2002

Press [Up] / [Down] arrows to display second half of version date.

The second half of the version date will be displayed as XXX (time in 6 minute intervals): For example, 36.0 = 36 minutes

Transferring Software From Luminaire to Luminaire

It is possible to transfer specific software versions between luminaires. As in the case of installing new software versions, multiple luminaires can be programmed at the same time if they are data linked together (refer to “[Connecting Data and Power](#)” on page 18), however a maximum of 32 luminaires can be updated at once.

The transfer process can be used to download an earlier or later version of the *Luminaire Software* to other connected luminaires.

Hardware Requirements

Data cables used in this process must have two twisted pairs and a shield. It is also recommended that cables meet all other USITT DMX specification requirements. Refer to “[Data Cables](#)” on page 11.

Loopback and termination connectors are used in this process. Refer to “[Male Termination Connector](#)” on page 13 for more information regarding the construction of these connectors.

Transfer Procedure

This procedure is used to transfer software versions between luminaires.

- Step 1. At master luminaire (first in link), install loopback connector into DATA IN XLR connector.
- Step 2. At last luminaire, install male termination connector into DATA THRU XLR connector.

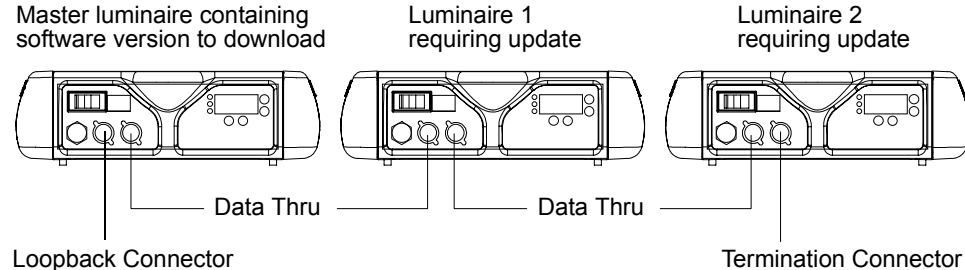



Figure 3-3: Software Transfer Setup

- Step 3. At master luminaire Menu Display, press [Menu].
- Step 4. Press [Up] / [Down] arrows until Fixture appears.
- Step 5. Press [Up] / [Down] arrows until Download appears. Press [Enter].
- Step 6. OK? will be displayed. Press [Enter] to accept.

Step 7. Download will proceed. (Download will take 1-2 seconds.) One of the following will occur:

- Correct**  The receiving luminaire's green Rx LED will blink rapidly and its menu will display number of blocks received (this number will vary depending on software version being downloaded). This indicates that data is being sent from luminaire to luminaire. However, if display does not show blocks as they are received, this indicates that the version being downloaded matches the one already installed or that the luminaire type does not match.
- Trouble**  If the receiving luminaire's green Rx LED does not blink rapidly and its menu does not display blocks, this indicates that no data is being received. (Check cable connections, Loopback Connector, etc. and ensure ALL cabling is the 5-conductor type.)

Note: Without any data connected, the normal standby cycle of the Rx LED is 2 sec on, 2 sec off.

Note: The number of blocks displayed will be less in a luminaire-to-luminaire download than in a PC-to-luminaire download for the same software version.

Step 8. Once download is complete, luminaire will automatically recalibrate. Once recalibration is complete, luminaire is ready for operation with its new software version.

Verify software version at luminaire:

- Step 1. At Menu Display, press [Menu].
- Step 2. Press [Up] / [Down] arrows until Fixt appears. Press [Enter].
- Step 3. Press [Up] / [Down] arrows until Ver appears. Press [Enter].

The first half of the version date will be displayed as MM/DD/YY (month/day/year): For example, 07/21/02 = July 21, 2002

Press [Up] / [Down] arrows to display second half of version date.

The second half of the version date will be displayed as XXX (time in 6 minute intervals): For example, 36.0 = 36 minutes

Notes



CHAPTER 4.

Menu System

This chapter contains instructions for operating the luminaire using the Menu Display feature.

- **Operation**
- **Mapping**
- **Cues and Sequences**
- **Self Tests**

Operation

What Is the Menu System?

The menu system is a programmable set of commands used to configure, address, operate, and test the luminaire. The menu system is controlled at the Menu Display available at the enclosure input panel.

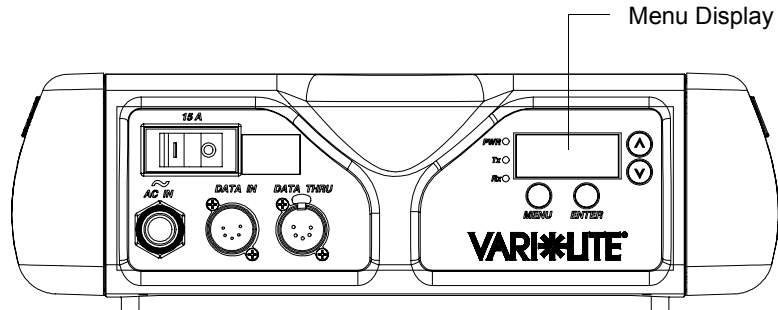

Figure 4-1: Menu Display Location

The menu system has seven main functions which are referred to as “1st level.” Within these main functions, there can be up to four additional sub-functions (levels 2 thru 5), making five total levels.

Controls Operation

The menu system is controlled by four buttons. These buttons function as follows:

[Menu] button. Displays the menu, or if at first level, the current address.

[Enter] button. Selects the current menu option or stores current data value.



[Up] arrow. Scrolls menu options upward or increases current data value.*



[Down] arrow. Scrolls menu options downward or decreases current data value.*

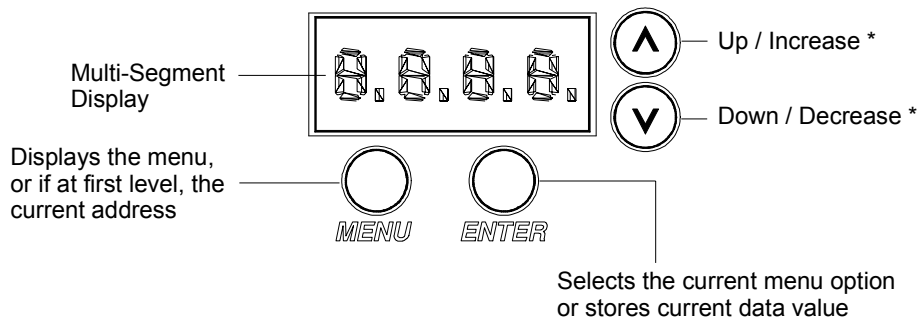
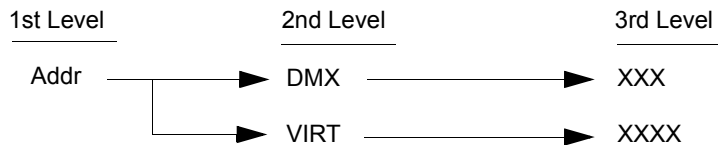

Figure 4-2: Controls Operation

* The arrows will have opposite functions if luminaire is hung upside down in a hanging orientation and the Display Direction Orientation is “flipped.” Refer to “[Display Orientation](#)” on page 45.

To enter the menu system, first press [Menu]. The functions displayed will be 1st level functions. Scroll through the 1st level functions by pressing [Up] / [Down] arrows. Once the desired function appears in the display, press [Enter]. You are now at the 2nd level. Once again, press the [Up] / [Down] arrows to scroll through 2nd level functions. Press [Enter] to access 3rd level functions and so forth. When the highest level for the function is reached, [Up] / [Down] arrows can be pressed to select a value or select a toggle activation such as ON/OFF. Press [Enter] to store the value or select an action.

For example, the Addr (Address) function has two sub-levels: DMX and VIRT (Virtuoso). Both of these 2nd level menus allow access to a 3rd level, which is a value in both of these functions. The Address function is a 3-level menu.



Display Orientation

To assist in reading the Menu System if the luminaire is installed in a hanging position, the display read-out orientation can be changed so that it still reads from left-to-right. Keep in mind that when the display read-out orientation is switched, the function of the [Up] / [Down] arrows are also switched respectively. In any case, when the display is in its readable orientation, the lower arrow functions as down/decrease and the upper arrow functions as up/increase.

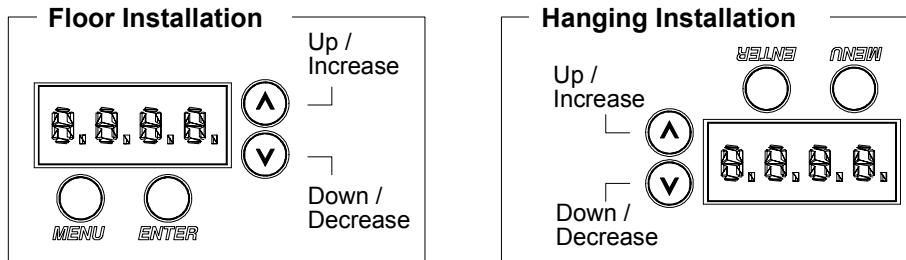

Figure 4-3: Display Orientation

The default setting for the display orientation is Auto, which will automatically detect the orientation of the luminaire and adjust the display accordingly. However, a fixed orientation can also be programmed.

To program a fixed display read-out orientation:

- Step 1. Press [Menu].
- Step 2. Press [Up] / [Down] arrows until CFG (Configuration) appears. Press [Enter].
- Step 3. Press [Up] / [Down] arrows to access DDir. Press [Enter].
- Step 4. Press [Up] / [Down] arrows to select ↑↑ or ↓↓. When desired direction is reached, press [Enter].

Default State

The menu display's default state during normal operation is to display the address (Virtuoso or DMX). After 10 seconds of inactivity at the display, it will change to the default state.

After longer periods of inactivity, the menu display will switch to its off state. The default state for this feature is 5 minutes, however, different time lengths can also be programmed.

To program a different time length for menu off feature:

- Step 1. Press [Menu].
- Step 2. Press [Up] / [Down] arrows until CFG (Configuration) appears. Press [Enter].
- Step 3. Press [Up] / [Down] arrows to access DisP (Display). Press [Enter].
- Step 4. Press [Up] / [Down] arrows to select either 30s (30 sec), 5M (5 minutes), 10M (10 minutes), or ON (on indefinitely). Press [Enter] to set.

Decimal Placement

A decimal to the right of a menu display readout can indicate two things:

- Virtuoso address - for example, XXXX.
- One of two pages - for example, the eight-digit luminaire ID number page 1: XXXX. and page 2: XXXX

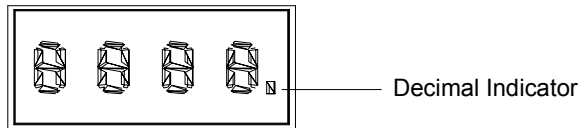

Figure 4-4: Decimal Indicator

Display Test

The Display Test will display every character on the menu display to check for missing characters.

The following procedure is used to test the display.

- Step 1. Press [Menu].
- Step 2. Press [Up]/[Down] until Test appears. Press [Enter].
- Step 3. Press [Up]/[Down] until DISP appears. Press [Enter]. All segments in the alpha-numeric display should be lit.

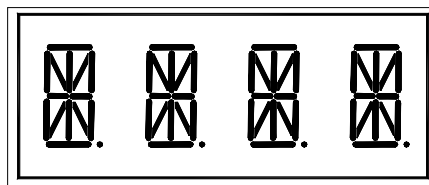

Figure 4-5: Display Test

Shortcuts

A few button combinations are provided as shortcuts for frequently used menu functions. These shortcuts are as follows:

- Pressing [Enter] and [Up] at the same time = Lamp On
- Pressing [Enter] and [Down] at the same time = Lamp Off
- Pressing [Menu] and [Up] at the same time = Recalibrate
- Pressing [Menu] at Power up interrupts calibration. See [“Program Starting Address Without Calibrating the Luminaire” on page 22](#) for more information.

Keep in mind that [Up] and [Down] arrows are dependent on the Display Orientation. Refer to [“Display Orientation” on page 45](#).

Mapping

Menu System Overview

The following is a graphic representation of the entire menu system.

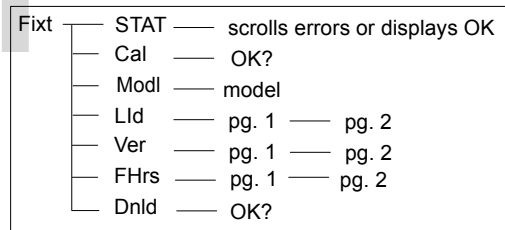
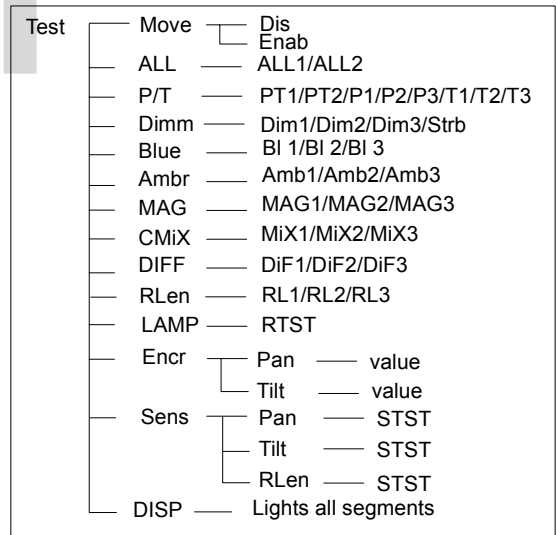
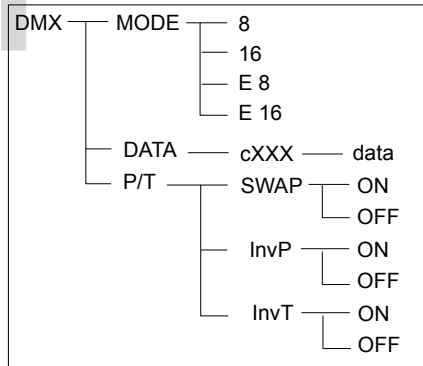
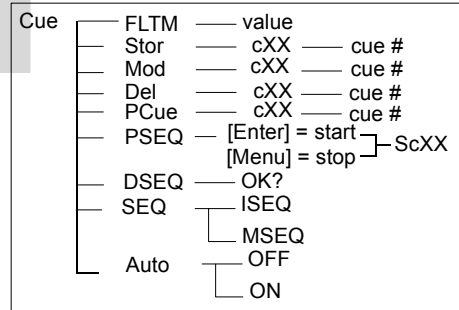
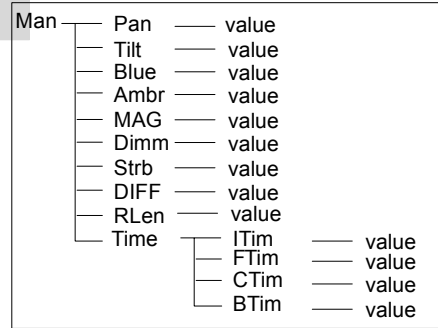
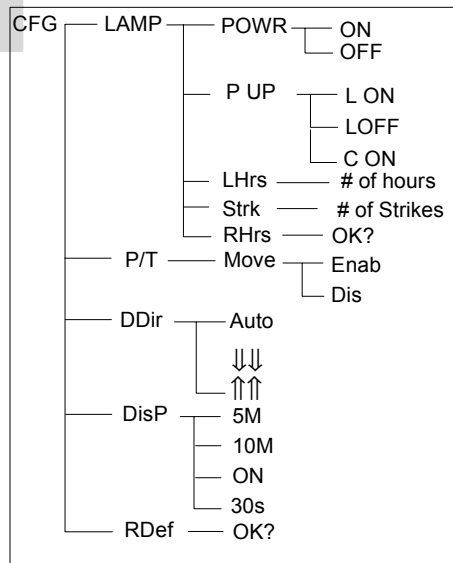
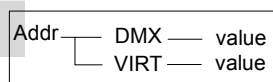

Menu System Functions

The following table is a detailed structure of the menu system.

1st Level	2nd Level	3rd Level	4th Level	5thLevel
Addr Address	DMX DMX Address	XXX Address value		
	VIRT Virtuoso Address	XXXX. Address value		
CFG System Configuration	LAMP Lamp Options	POWR Lamp Power (ARC ONLY)	ON (default) OFF	
		P UP Lamp Power-up State (ARC ONLY)	L ON Lamp is on (default)	
			LOFF Lamp is off	
			C ON On after Calibration	
		LHrs Bulb Hours Used	XXXX Cumulative # of Operation Hours (Not editable)	
		Strk # of Lamp Strikes (ARC ONLY)	XXXX # of Strikes	
		RHrs Reset Lamp Hour Counter and Lamp Strike Counter	OK?	
	Bulb Bulb Voltage Type (Incandescent Only)			
	P/T Pan and Tilt Options	Move Position Recovery	Enab Enable	
			Dis Disable	
	DDir Display Orientation	Auto (default)		
		↓↓↓		
		↑↑↑		
	DisP Display Illumination	30s OFF in 30 seconds		
		5M OFF in 5 minutes (default)		
		10M OFF in 10 minutes		
		ON ON indefinitely		
RDef Reset Default Values	OK?			
DMX DMX Mode and Data	MODE	8 Standard 8 bit		
		16 Standard 16 bit (default)		
		E 8 Enhanced 8 bit		
		E16 Enhanced 16 bit		
	DATA	cXXX DMX Channel	XXXX Data	
	P/T Pan/Tilt Options	SWAP Swap Pan & Tilt	ON	
			OFF (default)	
		InvP Invert Pan	ON	
			OFF (default)	
	InvT Invert Tilt	ON		
OFF (default)				

VARILITE*® - VL2416™ WASH LUMINAIRE USER'S MANUAL**

1st Level	2nd Level	3rd Level	4th Level	5thLevel
Fixt	STAT	Scrolls error messages * or displays OK		
	Cal Recalibrate	OK?		
	Modl Luminaire Model Type	XXXX Model Type		
	Lld Luminaire ID	XXXX. Luminaire ID Number (Page 1)	XXXX Luminaire ID Number (Page 2)	
	Ver Version	XX.XX. Version (Page 1)	XX.XX Version (Page 2)	
	FHrs Fixture Hours On	XXXX Hours		
	Dnld Download Program to Luminaires	OK?		
Man Manual Commands	Pan Pan Motor	XXXX Data		
	Tilt Tilt Motor	XXXX Data		
	Blue Blue	XXX Data		
	Ambr Amber	XXX Data		
	MAG Magenta	XXX Data		
	Dimm Dimmer	XXX Data		
	Strb Strobe	XXX Data		
	DIFF Diffuser	XXX Data		
	RLen Rotating Lens	XXX Data		
	Time Timing Data	ITim Dimmer/Intensity Time	XXX.X Data	
	FTim Focus Time	XXX.X Data		
	CTim Color Time	XXX.X Data		
	BTim Beam Time	XXX.X Data		
Cue Cue Processing	FLTM Follow Time	XXX.X Data		
	Stor Store Cue	XX Cue # to Store (Not editable – given next cue ID in list)		
	Mod Modify Cue	XX List of Cues		
	Del Delete Cue	XX Cue # to Delete (Not editable – given last cue ID in list)		
	PCue Play Cue	XX List of Cues		
	PSEQ Play Sequence	Press [Enter] to start Press [Menu] to stop		
	DSEQ Delete Sequence	OK?		
	SEQ Sequence Playback Mode	ISEQ Individual Sequence (default)		
		MSEQ Master Sequence		
Auto Autoplay at Power-Up	OFF (default)			
	ON			

1st Level	2nd Level	3rd Level	4th Level	5thLevel
Test System Test	MOVE Pan/Tilt Control	Dis Disable	Press [Menu] to stop tests	
		Enab Enable		
	ALL Test All Motors	ALL1 All Synchronized Test		
		ALL2 All Test		
	P/T Pan/Tilt	PT 1 Min/Max Fast Pan/Tilt test		
		PT 2 Min/Max SlowPan/Tilt test		
		P 1 Min/Max Fast Pan Test		
		P 2 Min/Max Slow Pan Test		
		P 3 Pan Test		
		T 1 Min/Max Fast Tilt Test		
		T 2 Min/Max Slow Tilt Test		
		T 3 Tilt Test		
		Dimm Dimmer/Strobe		Dim1 Min/Max Dimmer Test
	Dim2 Min/Max Dimmer Test			
	Dim3 Dimmer Test			
	Strb Strobe Test			
	Blue Blue	BI 1 Min/Max Blue Test		
		BI 2 Min/Max Blue Test		
		BI 3 Blue Test		
	Ambr Ambr	Amb1 Min/Max Amber Test		
		Amb2 Min/Max Amber Test		
		Amb3 Amber Test		
	MAG Magenta	MAG1 Min/Max Magenta Test		
		MAG2 Min/Max Magenta Test		
		MAG3 Magenta Test		
	CMiX Color Mixer	MiX1 Color Mixer Test		
		MiX2 Color Mixer Test		
		MiX3 Color Mixer Test		
	DIFF Diffusion	DiF1 Min/Max Diffusion Test		
		DiF2 Min/Max Diffusion Test		
		DiF3 Diffusion Test		
	RLen Rotating Lens	RL 1 Rotating Lens Test		
		RL 2 Rotating Lens Test		
		RL 3 Rotating Lens Test		
	LAMP Lamp	LAMP Lamp Test		

VARI*LITE® - VL2416™ WASH LUMINAIRE USER'S MANUAL

1st Level	2nd Level	3rd Level	4th Level	5thLevel	
Test (cont.)	Encr Encoders	Pan Pan Encoder	XXXX Data		
		Tilt Tilt Encoder	XXXX Data		
	Sens Sensors	Pan Pan EOT Sensor		STST Sensor Test in Progress	PASS
					FAIL
		Tilt Tilt EOT Sensor		STST Sensor Test in Progress	PASS
					FAIL
		RLen Rotating Lens Sensor		STST Sensor Test in Progress	PASS
					FAIL
	DISP Display Test	X.X.X.X. Ignites all 14 segments of each of the 4 characters and all 4 decimal points.			

Note: A decimal to the right of a menu display readout indicates either a Virtuoso address or that the page is 1 of 2. Refer to [“Decimal Placement” on page 46.](#)

Function Definitions

Each menu item is listed in the first column by its display abbreviation. The abbreviations appear in alphabetical order as opposed to their position in the menu display sequence for easy reference.

Display	Definition	Purpose
8	Standard 8-bit	Configures luminaire for operation in standard DMX 8-bit mode.
16	Standard 16-bit	Configures luminaire for operation in standard DMX 16-bit mode.
10M	10 Minutes	Sets Menu Display to automatically shut off after 10 minutes of non-use.
30s	30 Seconds	Sets Menu Display to automatically shut off after 30 seconds of non-use.
5M	5 Minutes	Sets Menu Display to automatically shut off after 5 minutes of non-use.
Addr	Address	Accesses functions for setting luminaire starting address in either Virtuoso (VIRT) or DMX (DMX) controlled systems.
ALL	All Motors	Tests all internal motors.
Ambr	Amber	Specifies amber filter set for manual control.
Auto	Auto Detect or Auto Playback	Automatically detects required Menu Display orientation when selected (DDir) or initiates automatic playback of a cue sequence at power-up (CUE).
Blue	Blue	Specifies blue filter set for manual control.
BTim	Beam Time	Sets beam time.
C ON	On after Calibration	Configures arc luminaire so that lamp will strike after calibration procedure is complete.
Cal	Recalibrate	Recalibrates luminaire.
CFG	System Configuration	Accesses functions for setting lamp start up, pan/tilt, and Menu Display configurations. Also accesses lamp information such as number of strikes, and hours used, along with their respective reset function.
CTim	Color Time	Sets color time.
Cue	Cue Processing	Accesses cue store, modify, delete, and playback commands.
cXXX	DMX Channel	Specifies DMX channel for display of current data value.
DATA	DMX Data	Accesses function for displaying DMX data by channel number.
DDir	Display Orientation	Accesses option to orient Menu display for reading correctly in either hanging or floor mounting installations.
Del	Delete Cue	Deletes cues by number. Cue number deleted is dependent on last cue ID in cue list since this field is not editable.
Diff	Diffuser	Specifies diffuser mechanism for manual control and testing.
Dimm	Dimmer	Specifies dimmer mechanism for manual control (Man) or tests dimmer/strobe functions (Test).
Dis	Disable	Disables a function.
DisP	Display	Accesses options for Menu Display on and off times.
DMX	DMX	Accesses functions for setting DMX mode or pan/tilt options (1st level menu) or sets starting address for luminaire in DMX systems (Addr).
Dnld	Download	Downloads program to luminaires.

Display	Definition	Purpose
DSEQ	Delete Sequence	Deletes cue sequence.
E 16	Enhanced 16-bit	Configures luminaire for operation in enhanced DMX 16-bit mode.
E 8	Enhanced 8-bit	Configures luminaire for operation in enhanced DMX 8-bit mode.
Enab	Enable	Enables a function.
Encr	Encoders	Accesses encoder choices for diagnostic testing.
FAIL	Test Fail	Indicates that sensor test has failed.
FHrs	Fixture Hours	Displays total number of hours luminaire has been powered on.
Fixt	Fixture	Access luminaire specification information such as model, serial number, software version, along with status information and download function.
FLTM	Follow Time	Sets time for cue follow feature.
FTim	Focus Time	Accepts timing value for focus time.
InvP	Invert Pan	Reverses pan action for special focus requirements.
InvT	Invert Tilt	Reverses tilt action for special focus requirements.
ISEQ	Individual Sequence	A sequence playback mode which will play the cues from each individual luminaire, if any. (In ISEQ, if the number of cues is different, it will only play as many as each luminaire has stored. The follow time is taken from the master luminaire.)
ITim	Intensity Time	Sets intensity fade time.
L ON	Lamp is On	Configures arc luminaire so that lamp will strike upon power up.
LAMP	Lamp	Accesses lamp power up options and information (CFG) and sets beam for lamp alignment adjustment (TEST).
LHrs	Lamp Hours	Displays total number of lamp operating hours.
Lid	Luminaire ID	Displays unique ID number for the luminaire which is used by Virtuoso consoles to identify the unit (in two pages).
LOFF	Lamp is Off	Configures arc luminaire so that lamp will await manual command before striking.
MAG	Magenta	Specifies magenta color filter set for manual control.
Man	Manual Commands	Accesses functions for controlling luminaire mechanisms and timing by entry of an absolute data value.
Mod	Modify Cue	Accepts cue number of cue to modify from cue list.
MODE	DMX Mode	Accesses functions for setting DMX mode to standard or enhanced 8-bit or 16-bit.
Modl	Model	Displays model number of luminaire. For example, 2416 (VL2416).
Move	Move	Enables and disables pan and tilt movement and auto-correction.
MSEQ	Master Sequence	A sequence playback mode which will replay the cues from the master luminaire.
NoPg	No Program	Indicates that there is no software present in the luminaire.
OFF	Off	Turns off a function.
OK	Okay	Indicates that luminaire is ready to accept commands.
OK?	Okay	Prompt for pressing [Enter] before an action is executed.

Display	Definition	Purpose
ON	On Indefinitely	Sets Menu Display to stay on until programmed otherwise (DisP) or turns on a function.
P UP	Lamp Power Up	Accesses options for lamp power up: on, off, or after calibration.
P/T	Pan/Tilt	Accesses pan and tilt options for DMX function, system configuration, and testing.
Pan	Pan	Specifies pan function for manual control (Man) or pan encoder for testing (Test).
PASS	Test Pass	Indicates that sensor test has passed.
PCue	Play Cue	Accesses cue list for play back of cues by number.
POWR	Lamp Power	Accesses function to turn lamp on or off.
PSEQ	Play Sequence	Plays back cue sequence. Press [Enter] to start and [Menu] to stop.
RDef	Reset Default	Resets default system configuration values.
RHrs	Reset Lamp Info	Resets lamp hour and lamp strike counters. For use when new lamp is installed.
RLen	Rotating Lens	Specifies rotating lens for manual control (Man) or rotating lens sensor for testing (Test).
RTST	Run-Test	Indicates that a system mechanism test is in progress.
SCR	Source Parameters	Accesses incandescent lamp source voltage input/output and current output information.
Sens	Sensors	Accesses sensor choices for diagnostic testing.
SEQ	Sequence Playback	Sets sequence playback mode to Individual (plays cues from each luminaire) or Master (all luminaires play same cue).
STAT	Status/Error Display	Allows scrolling through error list or displays OK if no errors.
Stor	Store Cue	Stores cue by number. Cue number stored is dependent on next cue ID in cue list since this field is not editable.
Strb	Strobe	Specifies strobe function for manual control.
Strk	Strike	Displays total number of lamp strikes.
STST	Sensor Test	Indicates that a system sensor test is in progress.
SWAP	Swap	Swaps pan and tilt functions for special focus requirements such as moving mirror mechanisms.
Test	System Tests	Accesses diagnostic tests for internal mechanisms.
Tilt	Tilt	Specifies tilt function for manual control (Man) or tilt encoder for testing (Test).
Time	Timing Data	Allows manual setting of timing values for dimmer/intensity, focus, color, and beam.
Ver	Version	Displays current software version (in two pages).
VIn	Voltage IN	Indicates voltage input for incandescent models.
VOut	Voltage OUT	Indicates voltage output for incandescent models.

Cues and Sequences

Overview

The luminaire has the ability to store and playback cues independent of a console. Cues are stored as numbers from 1 to 99 by using the Cue (Cue Processing) functions available in the menu system. This also allows you to create your own test sequence to be played back on a group of luminaires.

Refer to [“Menu System Functions” on page 49](#) for a complete breakdown of Cue and Man (Manual Commands) functions.

Storing

The luminaire is able to store its current position into a cue; this information can be set via a console or by using the menu system Man (Manual Commands) function.

Playback

Cues can be joined into a sequence to be played back without a console. However, only one sequence can run at a time.

A sequence can either replay the cues stored in each luminaire or replay the cues stored in a master luminaire. Playing a cue sequence for all luminaires in the data link is triggered by a “master” luminaire using the PSEQ (Play Sequence) command. The cue follow time (FLTM) is taken from the luminaire that is running the sequence (it is possible to view the follow time of each cue by playing the cue PCUE and then viewing the cue follow time FLTM). A playback sequence can be set to start automatically after power up by setting the Auto (AutoPlay) feature to ON.

Note: Up to 32 luminaires can be linked together to run a sequence if they are data linked together. Refer to [“Connecting Data and Power” on page 18](#).

Hardware Requirements

Data cables used in the multi-luminaire playback feature must have two twisted pairs and a shield. It is also recommended that cables meet all other USITT DMX specification requirements. Refer to [“Data Cables” on page 11](#).

Loopback and termination connectors are used in this process. Refer to [page 13](#) for more information regarding the construction of these connectors.

Cue Operations

The following section provides instructions for performing cue, sequence, and playback operations.

Note: The Mod, Del, PCue, PSEQ commands will all display "---" if no cues have been stored.

Note: After 10 seconds of inactivity at the display, it will change to the default state showing the address.

To use the menus:

The data stored by the luminaire is “last takes precedence.” This means the last command received by the luminaire will be the basis of the cue to be stored.

To clear all input data and timing values from previous tests or cues, cycle power to the luminaire with DMX data cables disconnected. This will reset parameter’s data and timing values to defaults.

Set position:

- Step 1. Press [Menu].
- Step 2. Press [Up] / [Down] arrows until **Man** appears. Press [Enter].
- Step 3. Press [Up] / [Down] arrows until desired parameter appears. Press [Enter].
- Step 4. Press [Up] / [Down] arrows to adjust value. (The values wrap from 0 to 255 in either direction. Pan and Tilt values operate in a range of 0-4095, and wrap also.) Press [Enter] to set value.
- Step 5. Parameter timing can be set using the **Time** sub-functions. This allows timing to be added to Intensity, Pan & Tilt, Color, and Beam parameters.

Set follow time between cues:

The following procedure is used to set the follow time between each cue. The value can be different for each cue. The range is 0.0 to 365.9 seconds.

- Step 1. Press [Menu].
- Step 2. Press [Up] / [Down] arrows until **Cue** appears. Press [Enter].
- Step 3. Press [Up] / [Down] arrows until **FLTM** appears. Press [Enter].
- Step 4. Press [Up] / [Down] arrows to set value. Once the value is set press [Enter] button. The display will return to **FLTM**.

To store a cue:

- Step 1. Press [Menu].
- Step 2. Press [Up] / [Down] arrows until **Cue** appears. Press [Enter].
- Step 3. Press [Up] / [Down] arrows until **Stor** appears. Press [Enter]. The number displayed is the cue number to be stored.
- Step 4. Press [Enter] to store cue. (Number will increase by one for next cue to be stored.)
- Step 5. Repeat for remaining cues.

To delete a cue:

- Step 1. Press [Menu].
- Step 2. Press [Up] / [Down] arrows until **Cue** appears. Press [Enter].
- Step 3. Press [Up] / [Down] arrows until **Del** appears. Press [Enter]. The last cue number stored will be displayed and only the last cue will be deleted.
- Step 4. Press [Enter] to delete cue. (There is no “undo” function.)

To play a cue:

- Step 1. Press [Menu].
- Step 2. Press [Up] / [Down] arrows until **Cue** appears. Press [Enter].
- Step 3. Press [Up] / [Down] arrows until **PCue** appears. Press [Enter]. This allows the stored cues to be selected by using [Up] / [Down] arrows and then played by pressing [Enter]. (If there are no stored cues, “C --” will be displayed. If there is one or more cues, “C xx” will be displayed - where xx is the cue number from 1 to 99. Only cues in one luminaire will play.)

To edit or modify a cue:

- Step 1. Recall cue to be changed from **PCue**.
- Step 2. Change luminaire data to desired levels using **Man** (Manual Command) functions.
- Step 3. Press [Up] / [Down] arrows until **Cue** appears. Press [Enter].
- Step 4. Press [Up] / [Down] arrows until **Mod** appears. Press [Enter]. The number displayed is the same as the selected cue.
- Step 5. Press [Enter] and changes will be saved.

To play cues as a sequence:

- Step 1. Press [Menu].
- Step 2. Press [Up] / [Down] arrows until **Cue** appears. Press [Enter].
- Step 3. Press [Up] / [Down] arrows until **PSEQ** appears. Press [Enter] and the sequence will play. The active cue will be shown in the display. [Enter] to start, [Menu] to stop.

To change the follow time in a sequence:

The follow time is stored for each cue individually.

- Step 1. Select cue to be changed from PCue.
- Step 2. Go to **MOD** to modify active cue and press [Enter] to save the change.
- Step 3. Set **FLTM** (Follow Time) to desired value (refer to “[Set follow time between cues:](#)” on [page 57](#)).

To delete a sequence and all cues:

- Step 1. Press [Menu].
- Step 2. Press [Up] / [Down] arrows until **Cue** appears. Press [Enter].
- Step 3. Press [Up] / [Down] arrows until **DSEQ** appears. Press [Enter].
- Step 4. **OK?** prompt will appear. Press [Enter] to delete stored sequence.

Choose Sequence Mode:

MSEQ will replay the cues from the master luminaire.

ISEQ will play the cues from each individual luminaire, if any. In **ISEQ**, if the number of cues is different, it will only play as many as each luminaire has stored. The follow time is taken from the master luminaire.

- Step 1. Press [Menu].
- Step 2. Press [Up] / [Down] arrows until **Cue** appears. Press [Enter].
- Step 3. Press [Up] / [Down] arrows until **SEQ** appears. Press [Enter].
- Step 4. Press [Up] / [Down] arrows to toggle between **ISEQ** and **MSEQ**. Press [Enter] to select mode.

To make a sequence AutoPlay at power up:

- Step 1. Press [Menu].
- Step 2. Press [Up] / [Down] arrows until **Cue** appears. Press [Enter].
- Step 3. Press [Up] / [Down] arrows until **Auto** appears. Press [Enter].
- Step 4. Use [Up] / [Down] arrows to toggle between **OFF** (the default) and **ON**. Press [Enter] to select the mode.

To store cues from a console:

- Step 1. Clear memory by deleting cues or sequence, if required.
- Step 2. Recall cue at the console.
- Step 3. From **Cue** menu, set **FLTM**, then at **Stor** store cue. If each luminaire has separate data then store each cue into each luminaire. The sequence mode to use in this case would be **ISEQ**.

Self Tests

Running Parameter Tests

The luminaire is capable of running self tests by using the TEST menu functions. For complete details and values for each test refer to [“Diagnostic Tests” on page 62](#).

Note: After 10 seconds of inactivity, the menu display will change to the default state showing the address.

When running tests on multiple luminaires, a loopback connector is required at the master luminaire (first in link) and a male termination connector is required at the last luminaire in the link. (Refer to [page 13](#) for more information regarding the construction of these connectors.)

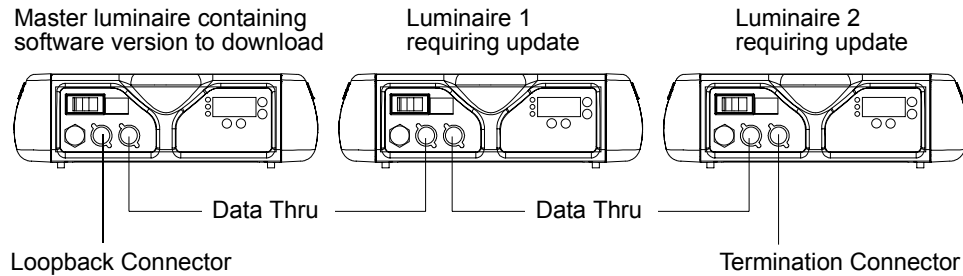

Figure 4-6: Test Setup

To run tests:

- Step 1. Press [Menu].
- Step 2. Press [Up] / [Down] arrows until **Test** appears. Press [Enter].
- Step 3. Use [Up] / [Down] arrows to select a parameter to test. Refer to [“Menu System Functions” on page 49](#) for a complete list of test parameters which can be chosen.
- Step 4. Press [Enter] to run test.
- Step 5. Press [Menu] to stop test at any time.

Movement Disable

The **Movement** option allows pan and tilt to be disabled so that the luminaire can be placed in any position for testing without movement occurring. In order to regain full control of the luminaire, **Movement** will need to be enabled after testing.

Note: When using the **Movement** option, pan and tilt will be disabled for all the luminaires that are linked.

To set movement option:

- Step 1. Press [Menu].
- Step 2. Press [Up] / [Down] arrows until **Config** appears. Press [Enter].
- Step 3. Press [Up] / [Down] arrows until **Pan/Tilt** appears. Press [Enter].
- Step 4. **Movement** will be displayed. Press [Enter].
- Step 5. Use [Up] / [Down] arrows to select **Enable** or **Disable**. Press [Enter] to select.

Diagnostic Tests

The following diagnostic tests are available in the test menu. Time is specified for each action in the test, and the total time equals the time it takes to complete each action. If the time is zero the luminaire will perform the test at full speed.

Note: The chart on the following page shows the 16-bit DMX values used in each test.

Test Description (in alphabetical order)

ALL1	Tests low voltage power supplies by moving all motors at once.
ALL2	Tests all functions and provides a burn in or soak test.
BI 1/Amb1/MAG1	Fast color mixer tests, Goes from full color to open.
BI 2/Amb2/MAG2	Slow color mixer tests, Goes from full color to open.
BI 3/Amb3/MAG3	Tests different color mixer positions.
DiF1	Fast diffusion test from stop to stop.
DiF2	Slow diffusion test from stop to stop.
DiF3	Tests different diffusion positions.
Dim1	Fast dimmer test from full to closed.
Dim2	Slow dimmer test from full to closed.
Dim3	Tests different dimmer moves.
RL 1	Slow lens test.
RL 2	Fast lens test.
RL 3	Test different lens movements.
MiX1	Fast color mixer test where all colors are operating.
MiX2	Slow color mixer test where all colors are operating.
MiX3	Tests different positions with all colors operating. Verifies the color match.
PT1	Fast pan and tilt from stop to stop.
PT2	Slow pan and tilt from stop to stop.
P 1	Fast pan only test from stop to stop.
P 2	Slow pan only test from stop to stop.
P 3	Tests different pan movements.
T 1	Fast tilt only test from stop to stop.
T 2	Slow tilt only test from stop to stop.
T 3	Tests different tilt movements.
Strb	Strobe test that tests 0-Open, 4-Closed, 11-Fast Random, 255-Max Strobe actions.

Table 4-1: Diagnostic DMX Values

Test Name	Parameters									
	Pan*	Tilt*	Dim	Diff	Lens	Blue	Ambr	MAG	Strb	time/total time
ALL1	0	0	0	0	0	0	0	0	0	0/7
	65535	65535	255	255	255	255	255	255	255	0/7
ALL2	0	0	0	255	0	0	0	0	0	0/7
	65535	65535	255	255	0	255	255	255	0	0/7
	0	0	0	0	0	0	0	0	0	0/7
	65535	65535	255	255	0	255	255	255	0	0/7
	0	0	0	255	0	0	0	0	0	9/9 (P/T only)
	65535	65535	255	255	0	255	255	255	0	9/9 (P/T only)
	0	0	0	0	0	0	0	0	0	9/9 (P/T only)
	65535	65535	255	255	0	255	255	255	0	9/9 (P/T only)
	45167	27000	255	0	0	255	0	0	0	0/3
	45167	27000	255	0	0	0	255	0	11	0/3
	45167	27000	255	0	0	255	0	0	0	0/2
	45167	27000	255	0	0	0	0	255	255	0/3
	45167	27000	255	128	71	110	255	0	0	0/3
	45167	27000	255	128	179	110	255	0	0	0/3
	45167	27000	255	255	128	110	255	0	0	0/3
	45167	27000	255	255	216	110	110	0	0	0/4
	45167	27000	255	128	143	0	110	110	0	0/4
	45167	27000	255	128	255	110	0	110	0	0/4
	45167	27000	255	0	0	110	0	0	0	0/3
	45167	27000	255	0	0	255	0	0	0	0/3
45167	27000	255	0	0	110	0	0	0	0/3	
ALL2 (cont.)	45167	27000	255	0	0	0	110	0	0	0/3
	45167	27000	255	0	0	0	255	0	0	0/3
	45167	27000	255	0	0	0	110	0	0	0/3
	45167	27000	255	0	0	0	0	110	0	0/3
	45167	27000	255	0	0	0	0	255	0	0/3
	45167	27000	255	0	0	0	0	110	0	0/3
	45167	27000	255	200	0	255	0	0	0	4/4 (Col only)
	45167	27000	255	0	0	0	255	0	0	4/4 (Col only)
	45167	27000	255	150	0	0	0	255	0	4/4 (Col only)
	45167	27000	255	0	225	121	121	0	0	0/4
	45167	27000	255	0	225	110	0	110	0	0/4
	45167	27000	255	0	245	118	118	121	0	0/4
	45167	27000	255	0	245	110	121	110	0	0/4
PT 1	0	0	0	0	0	0	0	0	0	0/7.5
	65535	65535	0	0	0	0	0	0	0	0/7.5

Table 4-1: Diagnostic DMX Values (Continued)

Test Name	Parameters									
	Pan*	Tilt*	Dim	Diff	Lens	Blue	Ambr	MAG	Strb	time/total time
PT 2	0	0	0	0	0	0	0	0	0	11/11
	65535	65535	0	0	0	0	0	0	0	11/11
P 1	0	54957	0	0	0	0	0	0	0	0/7.5
	65535	54957	0	0	0	0	0	0	0	0/7.5
P 2	0	54957	0	0	0	0	0	0	0	11/11
	65535	54957	0	0	0	0	0	0	0	11/11
P 3	33511	54957	0	0	0	0	0	0	0	0/3
	22227	54957	0	0	0	0	0	0	0	0/2.5
	35511	54957	0	0	0	0	0	0	0	0/2.5
	22227	54957	0	0	0	0	0	0	0	0/2.5
	44423	54957	0	0	0	0	0	0	0	0/3.5
	39401	54957	0	0	0	0	0	0	0	0/2.5
	44423	54957	0	0	0	0	0	0	0	0/2.5
	34901	54957	0	0	0	0	0	0	0	0/2.5
P 3 (cont.)	65535	54957	0	0	0	0	0	0	0	0/4
	0	54957	0	0	0	0	0	0	0	0/7
T 1	45167	0	0	0	0	0	0	0	0	0/4
	45167	65535	0	0	0	0	0	0	0	0/4
T 2	45167	0	0	0	0	0	0	0	0	8/8
	45167	65535	0	0	0	0	0	0	0	8/8
T 3	45167	32767	0	0	0	0	0	0	0	0/2
	45167	11207	0	0	0	0	0	0	0	0/2
	45167	4487	0	0	0	0	0	0	0	0/2
	45167	11207	0	0	0	0	0	0	0	0/2
	45167	4487	0	0	0	0	0	0	0	0/2
	45167	64555	0	0	0	0	0	0	0	0/4
	45167	54957	0	0	0	0	0	0	0	0/2.1
	45167	47677	0	0	0	0	0	0	0	0/2
	45167	54957	0	0	0	0	0	0	0	0/2
	45167	65535	0	0	0	0	0	0	0	0/2
Dim1	45167	27000	255	0	0	0	0	0	0	0/0.5
	45167	27000	0	0	0	0	0	0	0	0/0.5
Dim2	45167	27000	255	0	0	0	0	0	0	6.5/6.5
	45167	27000	0	0	0	0	0	0	0	6.5/6.5

Table 4-1: Diagnostic DMX Values (Continued)

Test Name	Parameters									
	Pan*	Tilt*	Dim	Diff	Lens	Blue	Ambr	MAG	Strb	time/total time
Dim3	45167	27000	255	0	0	0	0	0	0	0/0.5
	45167	27000	128	0	0	0	0	0	0	0/0.5
	45167	27000	80	0	0	0	0	0	0	0/0.5
	45167	27000	100	0	0	0	0	0	0	0/0.5
	45167	27000	40	0	0	0	0	0	0	0/0.5
	45167	27000	50	0	0	0	0	0	0	0/0.5
	45167	27000	40	0	0	0	0	0	0	0/0.5
	45167	27000	60	0	0	0	0	0	0	0/0.5
	45167	27000	0	0	0	0	0	0	0	0/0.5
Strb	45167	27000	0	0	0	0	0	0	0	0/1
	45167	27000	0	0	0	0	0	0	4	0/1
	45167	27000	0	0	0	0	0	0	0	0/1
	45167	27000	0	0	0	0	0	0	4	0/1
	45167	27000	0	0	0	0	0	0	11	0/4
	45167	27000	0	0	0	0	0	0	0	0/1
	45167	27000	0	0	0	0	0	0	255	0/3
	45167	27000	0	0	0	0	0	0	4	0/1
	45167	27000	0	0	0	0	0	0	255	0/3
BI 1	45167	27000	0	0	0	255	0	0	0	0/0.4
	45167	27000	0	0	0	0	0	0	0	0/0.4
BI 2	45167	27000	0	0	0	255	0	0	0	7/7
	45167	27000	0	0	0	0	0	0	0	7/7
BI 3	45167	27000	0	0	0	255	0	0	0	0/0.4
	45167	27000	0	0	0	0	0	0	0	0/0.4
	45167	27000	0	0	0	200	0	0	0	0/0.4
	45167	27000	0	0	0	150	0	0	0	0/0.4
	45167	27000	0	0	0	175	0	0	0	0/0.4
	45167	27000	0	0	0	170	0	0	0	0/0.4
	45167	27000	0	0	0	190	0	0	0	0/0.4
	45167	27000	0	0	0	50	0	0	0	0/0.4
	45167	27000	0	0	0	220	0	0	0	0/0.4
	45167	27000	0	0	0	200	0	0	0	0/0.4
	45167	27000	0	0	0	205	0	0	0	0/0.4
	45167	27000	0	0	0	100	0	0	0	0/0.4
	45167	27000	0	0	0	255	0	0	0	0/0.4
	45167	27000	0	0	0	100	0	0	0	0/0.4
Amb1	45167	27000	0	0	0	0	255	0	0	0/0.4
	45167	27000	0	0	0	0	0	0	0	0/0.4
Amb2	45167	27000	0	0	0	0	255	0	0	7/7
	45167	27000	0	0	0	0	0	0	0	7/7

Table 4-1: Diagnostic DMX Values (Continued)

Test Name	Parameters									
	Pan*	Tilt*	Dim	Diff	Lens	Blue	Ambr	MAG	Strb	time/total time
Amb3	45167	27000	0	0	0	0	255	0	0	0/0.4
	45167	27000	0	0	0	0	0	0	0	0/0.4
	45167	27000	0	0	0	0	200	0	0	0/0.4
	45167	27000	0	0	0	0	150	0	0	0/0.4
	45167	27000	0	0	0	0	175	0	0	0/0.4
	45167	27000	0	0	0	0	170	0	0	0/0.4
	45167	27000	0	0	0	0	190	0	0	0/0.4
	45167	27000	0	0	0	0	50	0	0	0/0.4
	45167	27000	0	0	0	0	220	0	0	0/0.4
	45167	27000	0	0	0	0	200	0	0	0/0.4
	45167	27000	0	0	0	0	205	0	0	0/0.4
	45167	27000	0	0	0	0	100	0	0	0/0.4
	45167	27000	0	0	0	0	255	0	0	0/0.4
	45167	27000	0	0	0	0	100	0	0	0/0.4
MAG1	45167	27000	0	0	0	0	0	255	0	0/0.4
	45167	27000	0	0	0	0	0	0	0	0/0.4
MAG2	45167	27000	0	0	0	0	0	255	0	7/7
	45167	27000	0	0	0	0	0	0	0	7/7
MAG3	45167	27000	0	0	0	0	0	255	0	0/0.4
	45167	27000	0	0	0	0	0	0	0	0/0.4
	45167	27000	0	0	0	0	0	200	0	0/0.4
	45167	27000	0	0	0	0	0	150	0	0/0.4
	45167	27000	0	0	0	0	0	175	0	0/0.4
	45167	27000	0	0	0	0	0	170	0	0/0.4
	45167	27000	0	0	0	0	0	190	0	0/0.4
	45167	27000	0	0	0	0	0	50	0	0/0.4
MAG3 (cont.)	45167	27000	0	0	0	0	0	220	0	0/0.4
	45167	27000	0	0	0	0	0	200	0	0/0.4
	45167	27000	0	0	0	0	0	205	0	0/0.4
	45167	27000	0	0	0	0	0	100	0	0/0.4
	45167	27000	0	0	0	0	0	255	0	0/0.4
MiX1	45167	27000	0	0	0	0	255	0	0	0/0.4
	45167	27000	0	0	0	255	0	255	0	0/0.4
MiX2	45167	27000	0	0	0	0	255	0	0	7/7
	45167	27000	0	0	0	255	0	255	0	7/7

Table 4-1: Diagnostic DMX Values (Continued)

Test Name	Parameters									
	Pan*	Tilt*	Dim	Diff	Lens	Blue	Ambr	MAG	Strb	time/total time
MiX3	45167	27000	0	0	0	255	255	255	0	0/2
	45167	27000	0	0	0	0	190	200	0	0/2
	45167	27000	0	0	0	200	170	150	0	0/2
	45167	27000	0	0	0	150	175	175	0	0/2
	45167	27000	0	0	0	175	150	170	0	0/2
	45167	27000	0	0	0	170	200	190	0	0/2
	45167	27000	0	0	0	190	0	50	0	0/2
	45167	27000	0	0	0	50	205	220	0	0/2
	45167	27000	0	0	0	220	200	200	0	0/2
	45167	27000	0	0	0	200	220	205	0	0/2
	45167	27000	0	0	0	205	50	0	0	0/2
	45167	27000	0	0	0	255	100	0	0	0/2
	45167	27000	0	0	0	100	255	120	0	0/2
	45167	27000	0	0	0	120	100	255	0	0/2
	45167	27000	0	0	0	0	120	100	0	0/2
DiF1	45167	27000	0	255	0	0	0	0	0	0/2
	45167	27000	0	0	0	0	0	0	0	0/2
DiF2	45167	27000	0	255	0	0	0	0	0	4.5/4.5
	45167	27000	0	0	0	0	0	0	0	4.5/4.5
DiF3	45167	27000	0	245	0	0	0	0	0	0/2
	45167	27000	0	200	0	0	0	0	0	0/2
	45167	27000	0	230	0	0	0	0	0	0/2
	45167	27000	0	175	0	0	0	0	0	0/2
	45167	27000	0	50	0	0	0	0	0	0/2
	45167	27000	0	128	0	0	0	0	0	0/2
	45167	27000	0	100	0	0	0	0	0	0/2
	45167	27000	0	120	0	0	0	0	0	0/2
	45167	27000	0	5	0	0	0	0	0	0/2
	45167	27000	0	20	0	0	0	0	0	0/2
	45167	27000	0	0	0	0	0	0	0	0/2
RL1	45167	27000	0	0	107	0	0	0	0	0/3
	45167	27000	0	0	0	0	0	0	0	0/3
RL2	45167	27000	0	0	107	0	0	0	0	4/4
	45167	27000	0	0	0	0	0	0	0	4/4

Table 4-1: Diagnostic DMX Values (Continued)

Test Name	Parameters									
	Pan*	Tilt*	Dim	Diff	Lens	Blue	Ambr	MAG	Strb	time/total time
RL3	45167	27000	0	0	0	0	0	0	0	0/1
	45167	27000	0	0	50	0	0	0	0	0/1
	45167	27000	0	0	150	0	0	0	0	0/1
	45167	27000	0	0	200	0	0	0	0	0/1
	45167	27000	0	0	175	0	0	0	0	0/1
	45167	27000	0	0	89	0	0	0	0	0/1
	45167	27000	0	0	216	0	0	0	0	0/3
	45167	27000	0	0	231	0	0	0	0	0/6
	45167	27000	0	0	240	0	0	0	0	0/6
	45167	27000	0	0	255	0	0	0	0	0/3

*Pan and Tilt values are 16-bit DMX and will be different from the values in the Man control display.

APPENDIX A.



Troubleshooting and Maintenance

This appendix provides instructions for troubleshooting and performing routine maintenance which may be necessary during the life of the luminaire.

- **Troubleshooting**
- **Routine Maintenance**



WARNING: All maintenance procedures are to be performed with power removed from the luminaire. Never remove covers or open front lens or backcap assemblies while lamp is in operation.

Troubleshooting

Error Messages

If a problem occurs during luminaire calibration, at the end of the calibration sequence the Menu Display will cycle through any applicable error message(s), one a time until the end of the list is reached. To review the error messages again, it will be necessary to access them using the Status function.

Refer to next page for a list of possible causes and remedies associated with the error messages.

To access error messages:

- Step 1. Press [Menu].
- Step 2. Press [Up] / [Down] arrows until Fixt (Fixture) appears. Press [Enter].
- Step 3. Press [Up] / [Down] arrows to access STAT. Press [Enter]. (Display will now scroll through any error messages or display OK if no errors.)

Table A-1: Error Messages

Display	Message...
OK	No Errors Found
B2M1 / RLen / NoSn	Aux Board 2, Motor 1 / Rotating Lens / Sensor Not Found
B2M1 / RLen / SAct	Aux Board 2, Motor 1 / Rotating Lens / Sensor Always Active
BRD1 / NO / COMM	Aux Board 1 Communication Failure
BRD2 / NO / COMM	Aux Board 2 Communication Failure
HEAD / OVER / TEMP	Head Over Temperature
LAMP / STRK / FAIL	Lamp Strike Failure
PAN / ENCR / FAIL	Pan Encoder Failure
PAN / NO / SENS	Pan Sensor Not Found
PAN / SENS / ACTV	Pan Sensor Always Active
SCR / LOW / VOLT	SCR Dimmer / Low Voltage
SCR / NO / BULB	SCR Dimmer / No Bulb
SCR / OVER / CRNT	SCR Dimmer / Over Current
SCR / WRNG / BULB	SCR Dimmer / Wrong Bulb
SRCH/FOR/BRD1	Attempting to communicate with Board 1
SRCH/FOR/BRD2	Attempting to communicate with Board 2
TILT / ENCR / FAIL	Tilt Encoder Failure

Table A-1: Error Messages (Continued)

Display	Message...
TILT / NO / SENS	Tilt Sensor Not Found
TILT / SENS / ACTV	Tilt Sensor Always Active
WAIT	Retrieving Current Status
WRNG / SW / PROG	Wrong Software Program

Troubleshooting Guide

If a problem is suspected, first try recalibrating the luminaire to prompt an error message. The chart below provides possible causes and remedies for various error messages and/or symptoms.



CAUTION: Some troubleshooting is included for reference only. Performing remedies marked by gray areas will void product warranty. Refer to the Vari-Lite Limited Warranty card included with the product.

Table A-2: Troubleshooting Guide

Error Display	Description	Possible Cause and Remedy
B2M1 RLen NoSn	Aux Board 2, Motor 1, Rotating Lens, Sensor Not Found	Rotating lens power not connected, motor not moving - Connect motor power at motor - Rotating lens sensor not connected - Connect sensor Rotating lens movement restricted or impeded - Remove obstruction
		Rotating lens sensor is faulty - Replace sensor assembly Aux Board 2 is faulty - Replace aux board
B2M1 RLen SAct	Aux Board 2, Motor 1, Rotating Lens, Sensor Always Active	Rotating lens power not connected and lens aligned with sensor - Connect rotating lens power at motor
BRD1 NO COMM	Aux Board 1 Communication Failure	Aux input connector (J5) not connected to either aux board - Connect aux input connector (J5) to either aux board Jumper/bridge connector (J1) between aux boards not connected - Install jumper/bridge connector (J1) between aux boards

Table A-2: Troubleshooting Guide (Continued)

Error Display	Description	Possible Cause and Remedy
BRD2 NO COMM	Aux Board 2 Communication Failure	Aux input connector (J5) not connected to either aux board - Connect aux input connector (J5) to either aux board Jumper/bridge connector (J1) between aux boards not connected - Install jumper/bridge connector (J1) between aux boards
HEAD OVER TEMP	Head Over Temperature	One or both head fans not connected - Ensure both head fans are connected One or both head fans are faulty - Replace faulty head fan
LAMP STRK FAIL	Lamp Strike Failure	Lamp failed to strike after repeated attempts - Replace lamp
PAN ENCR FAIL	Pan Encoder Failure	Main board pan/tilt connector (J9) disconnected - Connect main board pan/tilt connector (J9) Pan motor disconnected - Connect pan motor power Encoder faulty - Replace pan end-of-travel/encoder sensor assembly
PAN NO SENS	Pan Sensor Not Found	EOT flag attached to large pulley is not engaging the EOT sensor - Ensure flag is attached to the large pulley - Ensure that flag passes through the sensor at a depth sufficient to engage the sensor beam Pan belt disconnected, extremely loose or not installed properly - Properly install belt between pan motor and large pulley
PAN SENS ACTV	Pan Sensor Always Active	Main board pan/tilt connector (J9) disconnected - Connect main board pan/tilt connector (J9) End-of-travel sensor connector (J2) disconnected - Connect end-of-travel sensor connector (J2)
SCR LOW VOLT	SCR Dimmer, Low Voltage	Insufficient voltage present for SCR dimmer to function properly - Correct voltage supply problem
SCR NO BULB	SCR Dimmer, No Bulb	No bulb installed - Install proper bulb to match line voltage
SCR OVER CRNT	SCR Dimmer, Over Current	Bulb power wires shorted - Replace bulb power wires SCR Dimmer board faulty - Replace SCR Dimmer board
SCR WRNG BULB	SCR Dimmer, Wrong Bulb	Wrong bulb installed for the available input voltage - Install proper bulb to match line voltage

Table A-2: Troubleshooting Guide (Continued)

Error Display	Description	Possible Cause and Remedy
SRCH/FOR/ BRD1 BRD2	Searching for Board 1 or 2	Attempting to communicate with Board 1 or Board 2. System will return either OK or an error code.
TILT ENCR FAIL	Tilt Encoder Failure	Main board pan/tilt connector (J9) disconnected - Connect main board pan/tilt connector (J9) Tilt motor disconnected - Connect tilt motor power Encoder faulty - Replace tilt end-of-travel/encoder sensor assembly
TILT NO SENS	Tilt Sensor Not Found	EOT flag attached to large pulley is not engaging the EOT sensor - Ensure flag is attached to the large pulley - Ensure that flag passes through the sensor at a depth sufficient to engage the sensor beam Tilt belt disconnected, extremely loose or not installed properly - Properly install belt between tilt motor and large pulley
TILT SENS ACTV	Tilt Sensor Always Active	Main board pan/tilt connector (J9) disconnected - Connect main board pan/tilt connector (J9) End-of-travel sensor connector (J2) disconnected - Connect end-of-travel sensor connector (J2)
WAIT	Retrieving Current Status	System displays wait while getting status.
WRNG SW PROG	Wrong Software Program	Software installed does not match luminaire type - Download the correct software for the luminaire

Routine Maintenance

Lamp Replacement



WARNING: Remove power from luminaire before performing maintenance.

Parts:

LAMP, 1200 WATT ARC (Vari-Lite part: 71.2528.1200)

To remove and replace lamp:

Step 1. Remove power from luminaire.



WARNING: Lamps will be extremely HOT after operation. Allow lamp to cool before replacing.

Step 2. At backcap assembly, open latch and swing open.

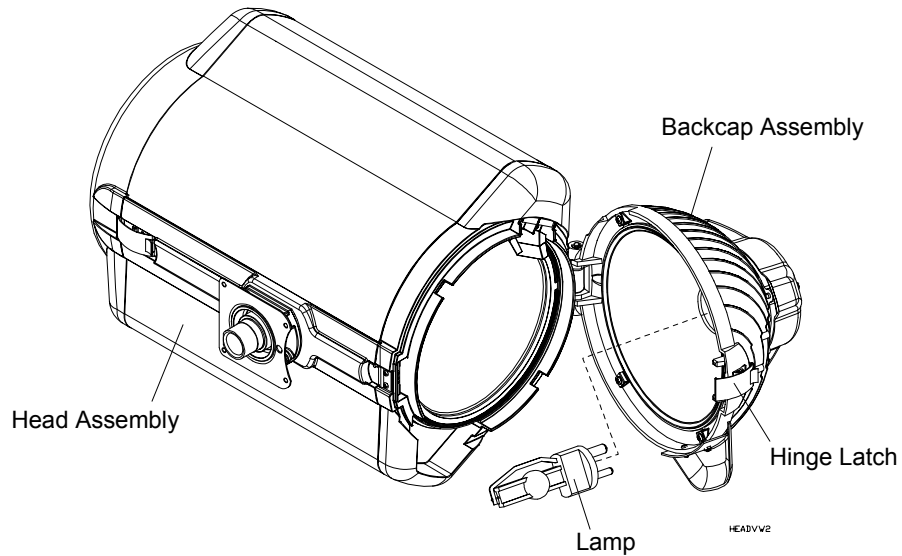

Figure A-1: Replacing Lamp



CAUTION: Wear cotton gloves or other covering while servicing lamp. Touching lamp glass with bare fingers will leave oil and may cause the lamp to explode or reduce lamp life. If required, use alcohol and soft, lint-free cloth to thoroughly clean glass portion of lamp.

- Step 3. Remove lamp by pulling straight out of socket.
- Step 4. Carefully clean reflector and facing UV glass lens with soft, lint-free cloth to remove dust and other debris.
- Step 5. Install lamp by pressing firmly into socket. Ensure lamp is fully seated in socket with base of lamp against socket base.
- Step 6. Close and latch backcap assembly.
- Step 7. If required, reset lamp hour and strike counters as follows. (Refer to [“Menu System” chapter on page 43](#) for more information.)
- Power up luminaire.
 - At Menu Display, press [Menu].
 - Press [Up] / [Down] arrows until CFG (Configuration) appears. Press [Enter].
 - Press [Up] / [Down] arrows until LAMP appears. Press [Enter].
 - Press [Up] / [Down] arrows to access RHrs. Press [Enter] to reset lamp hour and strike counters.
- Step 8. Align lamp. (Refer to [“Align Lamp for Flat Field” on page 20](#).)

Front Glass Replacement



WARNING: Remove power from luminaire before performing maintenance.

Parts:

as needed:

GLASS, FRONT, CLEAR (Vari-Lite part: 42.5002.0004)

GLASS, FRONT, STIPPLE (Vari-Lite part: 42.5002.0005)

GLASS, FRONT, MED. FLOOD 8-ROW LENT. (Vari-Lite part: 42.5002.0006)

GLASS, FRONT, MED. FLOOD 10-ROW LENT. (Vari-Lite part: 42.5002.0007)

GLASS, FRONT, MED. FLOOD 12-ROW LENT. (Vari-Lite part: 42.5002.0008)

GLASS, FRONT, VERY WIDE FLOOD - BUXOM (Vari-Lite part: 42.5002.0009)

To remove and replace front glass:

- Step 1. Remove power from luminaire.
- Step 2. At front ring assembly, open latch and swing open.

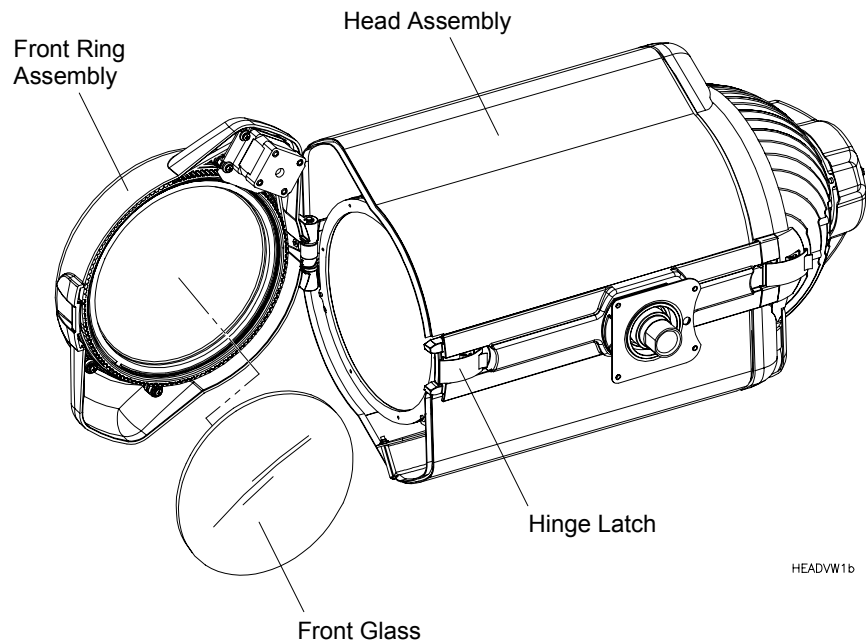

Figure A-2: Replacing Front Glass



CAUTION: Wear cotton gloves or other covering while handling front glass. If dirty, clean with common glass cleaner and a soft, lint-free cloth.

- Step 3. At front ring assembly, carefully press frontside of glass inward with thumbs while holding ring with fingers until glass is free of holder. Remove glass.

Note: The lenticular style glass requires calibration and must be installed in the orientation described in next step. The glass holder magnet is calibrated at the sensor for a RLens channel value of zero. Orienting the lens properly will achieve the same beam pattern from luminaire to luminaire.

- Step 4. **(Lenticular Glass Only)** For lenticular style glass, align center of large notch in glass with glass holder magnet. (Use metal object or screwdriver to assist in locating magnet, if necessary.)

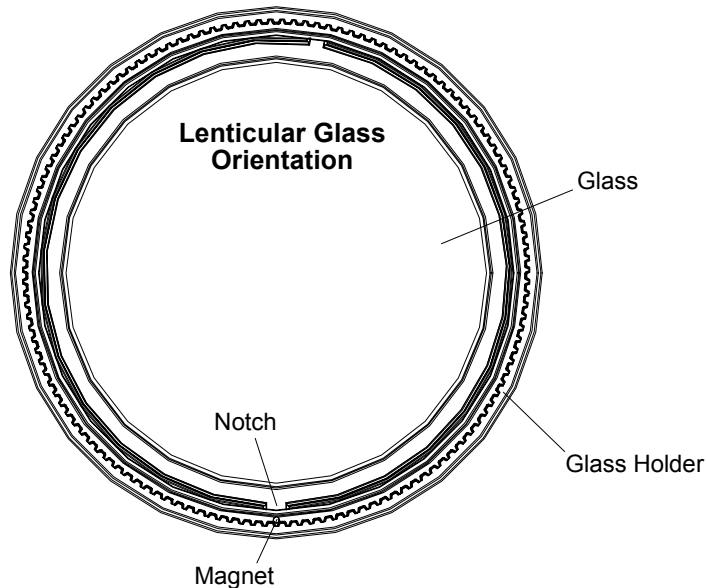

Figure A-3: Glass Alignment

- Step 5. Seat bottom portion of glass in glass holder and gently work fingers around glass, progressively seating it into holder.

Note: If there are problems with the lens fit, apply a small amount of Versilube to the nose ring pad.

- Step 6. Close and latch front ring assembly.

Cleaning Optical Lenses and Filters



WARNING: Remove power from luminaire before performing maintenance.

The front lens, color filters, and reflector may require cleaning after extended use. A common glass cleaner can be used along with a soft, lint-free cloth to clean these components.



CAUTION: Do not continuously rub filters or it may damage or remove the optical coating.

APPENDIX B.



Technical Specifications

Mechanical

Color

A DICHRO*TUNE radial color changing mechanism featuring independent blue, amber, and magenta color control capable of smooth, timed color crossfades or changes as fast as 0.35 seconds.

Intensity Control

An internal mechanical douser provides intensity control on all arc lamp units. An internal microprocessor-controlled SCR dimmer provides intensity control for units with incandescent lamps.

Beam Size Control

Zoomable beam spreader mechanism.

Rotating Lens

Continuous, rotatable, bi-directional, indexable front lens assembly. Factory lens is a light stipple. Accepts standard Par 64 cover lenses (optional). *Example: Smooth, Lenticular and Stipple.*

Pan and Tilt

Smooth, time-controlled continuous motion by way of a three-phase stepper motor system. Range: Pan - 540° , Tilt - 270°.

Pan/Tilt Accuracy

0.3° resolution.

Weight

63 lbs (28.6 kg).

Spacing

Refer to illustration on [page 17](#).

Optical

Source

1200 Watt Arc, 5400°K, 80CRI

Reflector

Precision glass reflector with dichroic cold mirror coating.

Operational

Power Requirements

All VL2416 models are powered through standard AC power distribution and require five amps to twelve amps depending on the AC supply voltage.

All VL2416 models operate from 200 to 240V AC 50/60 Hz

Operational Temperature

-20° to 113°F (-29° to 45°C)

Cooling

Forced air cooling.

Control

Compatible with the VARI*LITE Virtuoso™ control console and a wide variety of DMX consoles.

Mounting Position

The luminaire can be mounted and operated in any orientation.

Photometric

VL2416 Wash Luminaire - 1200 Watt Short Arc

(All data taken with a seasoned light source at 20 hours of life.)

DIFFUSION	CANDELA (cd)	BEAM ANGLE (degrees)	BEAM DIAMETER TN*	FIELD ANGLE (degrees)	FIELD DIAMETER TN*
Beam Spreader mechanism removed	5,800,000	2.0°	.035	5.5°	.096
Mechanism at full spot	1,960,000	4.0°	.070	8.5°	.149
Mechanism at 25% flood	440,000	10.0°	.175	18.0°	.317
Mechanism at 50% flood	148,000	18.5°	.326	31.0°	.555
Mechanism at 75% flood	72,000	27.0°	.480	45.0°	.828
Mechanism at full flood	43,200	33.5°	.602	55.0°	1.041

* Multiply throw distance by Tn to determine coverage.

To calculate Illuminance (I) at a specific distance (D): $I = \frac{cd}{D^2}$

Returning Parts for Service

Obtaining RMA Number and Returning Parts

1. Contact Service Center.
2. Request Return Material Authorization (RMA) number.
3. Do not remove glass color discs from luminaire subassemblies.
4. Package all parts being shipped. Please take great care in packing your items. Wrap all subassemblies and loose parts in bubble wrap or specialty packing material (if required) before shipping.
5. Fill in the form below and pack in box with parts.
6. Return parts and form to the following address:

Vari-Lite
RMA# _____
10911 Petal St.
Dallas, TX 75238

RMA Number: _____

Customer Name: _____

Fixture Serial Number: _____

Equipment Type: _____

Assembly: _____

Project: _____

Symptoms: _____

Suspected Fault: _____

Comments: _____

For Office Use Only

Technician		Date
Reported		
Repaired		
Logged		
Repairs Completed		

